



GME User's Guide

corresponding to model version
gmtri 2.30 and higher

D. Majewski, H. Frank and D. Liermann,
DWD, FE 13

Phone: + 49 69 8062 2718
+ 49 69 8062 2742
+ 49 69 8062 2732

E-Mail: Detlev.Majewski@dwd.de
Helmut.Frank@dwd.de
Doerte.Liermann@dwd.de

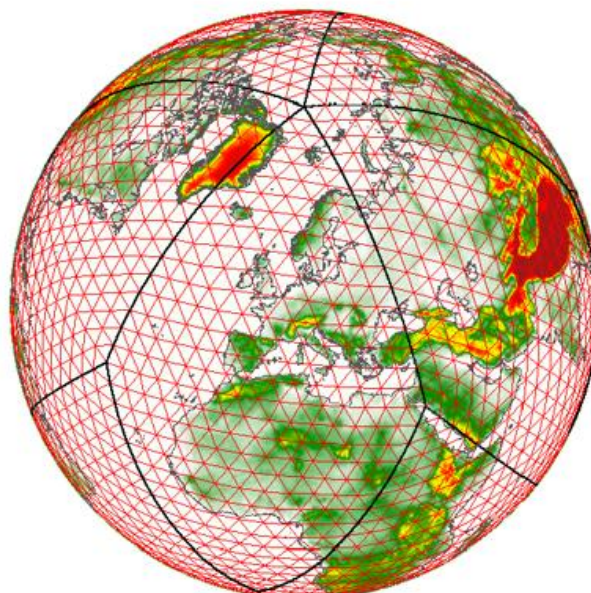

November 2012

Table of Contents

1. INTRODUCTION.....	2
2. HORIZONTAL GRID STRUCTURE.....	3
3. VERTICAL GRID.....	5
4. PARALLELISATION OF GME, 2D DOMAIN DECOMPOSITION.....	8
5. PHYSICAL PARAMETERIZATIONS.....	9
5.1. RADIATION AND CLOUDS.....	9
5.2. GRID-SCALE PRECIPITATION.....	9
5.3. CONVECTION.....	10
5.4. TURBULENT FLUXES IN THE ABL AND THE FREE ATMOSPHERE.....	11
5.5. SOIL MODEL.....	12
5.6. SSO SCHEME.....	14
5.7. SEA ICE MODEL.....	14
6. INITIAL STATE.....	14
7. INITIALIZATION.....	15
8. NAMELIST INPUT OF GME.....	16
8.1. INTRODUCTION.....	16
8.2. EXAMPLE OF INPUT_GME FILE.....	17
8.3. EXPLANATION OF THE DIFFERENT CONTROL VARIABLES AND SWITCHES.....	18
8.3.1. <i>&gme_ctl</i> - General control variables and switches.....	18
8.3.2. <i>&dyn_ctl</i> - Control variables and switches for the dynamics of GME.....	21
8.3.3. <i>&dfi_ctl</i> - Control variables and switches for the Digital Filtering Initialization.....	23
8.3.4. <i>&phy_ctl</i> - Control variables and switches for the physical parameterizations.....	24
8.3.5. <i>&dia_ctl</i> - Control variables and switches for diagnostics.....	26
8.3.6. <i>&met_ctl</i> - Control variables and switches for meteographs.....	28
8.3.7. <i>&gribin</i> - Control variables for the initial data (analysis/first guess).....	29
For idealized test cases, the NAMELIST group <i>&gribin</i> is replaced by the group <i>&artif_ctl</i>	29
8.3.8. <i>&artif_ctl</i> - Control variables for the definition of idealized test cases.....	29
8.3.9. <i>&gribout</i> - Control variables and switches for the GME post-processing.....	30
9. USING THE POST-PROCESSING FUNCTIONS.....	33
9.1. WRITING DATA ON THE ICOSAHEDRAL-HEXAGONAL MODEL GRID.....	33
9.2. WRITING DATA ON A REGULAR GEOGRAPHICAL (LATITUDE/LONGITUDE) GRID.....	33
10. FILE NAME CONVENTIONS.....	34
10.1. NAMING CONVENTION FOR DIRECTORIES.....	34
10.2. GENERAL FORM OF FILE NAMES OF GME.....	34
10.2.1. <i>Analysis files</i>	34
10.2.2. <i>Forecast files</i>	35
10.2.3. <i>Valid file headers (yhead)</i>	35
11. GRIB CODE TABLES OF GME VARIABLES.....	36
11.1. CONSTANT FIELDS (D=INVAR, D=1111MM1111).....	37
11.2. MULTI-LEVEL FIELDS ON MODEL LEVELS.....	38
11.3. FIELDS OF THE MULTI LAYER SOIL MODEL.....	39
11.4. SINGLE-LEVEL FIELDS.....	40
11.5. FIELDS INTERPOLATED TO PRESSURE LEVELS OR TO MSL.....	44
11.6. INITIAL FIELDS TO START GME.....	45
12. COMPUTER RESOURCES NEEDED BY GME.....	46
12.1. HORIZONTAL RESOLUTION AND NUMBER OF GRID POINTS PER LAYER.....	46
12.2. VERTICAL RESOLUTION.....	46
12.3. TOTAL MEMORY REQUIREMENTS.....	46

12.4.	TOTAL CPU REQUIREMENT OF GME	47
13.	NAMELIST INPUT OF IFS2GME.....	49
13.1.	INTRODUCTION	49
13.2.	EXAMPLE OF INPUT_IFS2GME FILE.....	51
13.3.	EXPLANATION OF THE DIFFERENT CONTROL VARIABLES AND SWITCHES	52
13.3.1.	<i>/ifs_grid/ - Control variables for the IFS grid.....</i>	<i>52</i>
13.3.2.	<i>/gme_grid/ - Control variables for the GME grid.....</i>	<i>52</i>
13.3.3.	<i>/data/ - Control variables and switches for the input and output data.....</i>	<i>53</i>
13.3.4.	<i>/dia/ Control variables and switches for diagnostics.....</i>	<i>54</i>
14.	COMPUTER RESOURCES NEEDED BY IFS2GME	55
15.	USAGE OF GME2GME	56
15.1.	INTRODUCTION AND OVERVIEW	56
15.2.	NAMELISTS AND DEFAULTS	57
15.2.1.	<i>/gme2gme_ctl/ - General control variables and switches</i>	<i>58</i>
15.2.2.	<i>/gribin/ - Declarations for INPUT data.....</i>	<i>59</i>
15.2.3.	<i>/gribout/ - Declarations for OUTPUT data.....</i>	<i>60</i>
15.2.4.	<i>/dia / - Diagnostics.....</i>	<i>60</i>
15.3.	EXAMPLES FOR INPUT_GME2GME	61
16.	APPENDIX: CALLING TREE FOR GME	65
16.1.	CALLING TREE FOR MAIN PROGRAM GMEORG	65
16.2.	CALLING TREE FOR TIME STEPPING ROUTINE PROGORG.....	66
16.3.	CALLING TREE OF SUBROUTINE PHYSICS.....	68
16.4.	CALLING TREE FOR POST-PROCESSING SUBROUTINE PPORG	69
17.	REFERENCES.....	70

Layout and word processing

Yvonne Schmidt-Reiter

This GME USER'S GUIDE is available in PDF format at:

http://portal.bvbs.bund.de/bvbw/generator/Sites/DWD/Content/FE/FE1/FE13/wir/Modelldokumenta-tionen/GME_Users_guide_aktuell.templateId=raw.property=publicationFile.pdf/GME_Users_guide_aktuell.pdf

1. Introduction

This GME User's Guide describes the latest version of the **global model GME** which became operational at DWD on 28 November 2012 06 UTC, and corresponds to the source code version *gmtri_2.30* and higher. With this version *GME* and *IFS2GME* can use GRIB API routines to read and write GRIB1 or GRIB2 data. This *GME* version 2.30 was made with GRIB API version 1.9.16. Be sure to include DWD specific GRIB definition tables in environment variable `GRIB_DEFINITION_PATH`. Otherwise some short names of GRIB API may not be known. In order to be able to use the libDWD GRIB1 library, too, the code must be compiled with the pre-processor option `-DGRIBDWD`. If *GME* is compiled without this option no restart files can be written and asynchronous IO cannot be used.

Operationally the GME uses a grid spacing of **20 km** and **60 layers** since 29 February 2012 12 UTC. In addition rain and snow particles are undergoing horizontal (and vertical) advection.

From 2 February 2010 until 29 February 2012 GME used a grid spacing of **20 km** and **60 layers** and from 27 September 2004 until 2 February 2010 GME used a grid spacing of **40 km** and **40 layers**. The former GME versions 1.xx being operational from 1 December 1999 up to 27 September 2004 00 UTC, used a grid spacing of **60 km** and **31 layers** and a two-layer soil model (i.e. source code version *gmtri_1.29.1.1*). As these code versions are incompatible, a separate User's Guide for the GME with the two-layer soil model is available.

Thus, for forecasts based on GME analyses for the period 1 December 1999 until 27 September 2004 00 UTC (with the 2-layer soil model) the code version *gmtri_1.29.1.21* has to be taken. For cases from 27 September 2004 12 UTC onwards GME code versions *gmtri_2.1* or higher have to be taken.

For the period from 1 December 1999 onwards the operational GME analysis (grid spacing 60 km / 31 layers until 27 September 2004 00 UTC and 40 km / 40 layers since 27 September 2004 12 UTC) is available as initial state for GME, too.

On 24 October 2007 new invariant data were introduced where land use is derived from the GLC2000 data set (<http://www-gvm.jrc.it/glc2000/>). In addition to the previous invariant data the new data set contains the various NDVI fields, the surface emissivity, and the minimal plant resistance. These fields are required to run version 2.13 or higher of GME.

Since version 2.20 aerosol is calculated from a monthly climatology of Tegen et al. (1997) for the five types dust, sulfat, organic aerosol, soot, and sea salt. Data for each type and month is required to start GME. Version 2.20 is run operationally since 23 September 2009.

Additionally, this User's Guide describes the control of the program *IFS2GME* which interpolates analyses (or forecasts) of the IFS (Integrated Forecasting System of the European Centre for Medium Range Weather Forecasts, ECMWF, Reading, UK; see <http://www.ecmwf.int>) to the GME grid. With the help of this program, either the re-analysis data of the ECMWF (ERA-40, from 1957 to 2001 with a horizontal resolution of T_L159 , ERA-Interim, from 1989 to present with resolution T_L255 , 60 layers) or the operational ECMWF analysis (currently T_L1279 , 91 layers; previously T_L799 , 91 layers) can be used as initial values for GME forecasts. Moreover, ECMWF forecast data can be interpolated by the program *IFS2GME* and can be used as first guess of a data assimilation step or re-labelled as analysis.

Finally there is a description of the program *GME2GME* which transforms between different GME grids; e.g. the initial state of GME with 20 km / 60 layers can be derived from 40 km / 40 layers data. In version 2.30 *GME2GME* cannot use GRIB API, yet.

2. Horizontal grid structure

The grid of GME is generated by inscribing an icosahedron with 20 triangles of equal size into the sphere. The spacing of the icosahedral-hexagonal grid of the GME is determined by the parameter n_i which is the number of intervals on a main triangle side (of a length of about 7054 km). Tables 2.1 and 2.2 give an overview of the grid characteristics for different values of n_i .

Table 2.1 Some characteristic quantities of the icosahedral-hexagonal grid at different resolutions given by n_i , the number of intervals on a main triangle side.

$N = 10 n_i^2 + 2$ is the number of grid points, A_{\min} is the minimum grid cell area, A_{\max} is the maximum grid cell area. Δ_{av} is the mean, Δ_{\min} the minimum, and Δ_{\max} the maximum distance between grid points.

Table 2.1a The main triangle side is halved q times, i.e. $n_i = 2^q$, where q is a positive integer.

q	n_i	N	A_{\min} (km ²)	A_{\max} (km ²)	Δ_{av} (km)	Δ_{\min} (km)	Δ_{\max} (km)
4	16	2562	154109	238061	477.6	440.5	526.0
5	32	10242	38515	59955	239.3	220.3	263.2
6	64	40962	9628	15017	119.8	110.1	131.6
7	128	163842	2407	3756	59.9	55.1	65.8
8	256	655362	602	939	30.0	27.6	32.9
9	512	2621442	150	235	15.0	13.8	16.5

Table 2.1b The main triangle side is first divided into three intervals, after that halved l times, i.e. $n_i = 3 * 2^l = 2^q$, where $q = 1.585 + l$.

q	n_i	N	A_{\min} (km ²)	A_{\max} (km ²)	Δ_{av} (km)	Δ_{\min} (km)	Δ_{\max} (km)
4.6	24	5762	68477	97683	319.0	293.7	346.9
5.6	48	23042	17117	24494	159.7	146.8	173.5
6.6	96	92162	4279	6128	79.9	73.4	86.8
7.6	192	368642	1070	1532	40.0	36.7	43.4
8.6	384	1474562	267	383	20.0	18.4	21.7
9.6	768	5898242	67	96	10.0	9.2	10.9

Since 29 February 2012 12 UTC $n_i = 384$, i.e. the mean grid spacing of GME is 20 km, and the mean grid cell is 346 km².

From 2 February 2010 12 UTC until 29 February 2012 $n_i = 256$, i.e. the mean grid spacing of GME is 30 km, and the mean grid cell is 778 km².

From 27 September 2004 12 UTC until 2 February 2010 $n_i = 192$, i.e. the mean grid spacing of GME is 40 km, and the mean grid cell is 1384 km².

From 1 December 1999 until 27 September 2004 00 UTC $n_i = 128$, i. e. the mean grid spacing of GME was 59.9 km, and the mean grid cell area was 3100 km².

Combining all grid points of two adjacent large triangles to a square matrix the global GME grid consists of 10 diamonds. The numbering of these diamonds is shown in Fig. 1.

Diamonds 1 to 5 originate at the north pole, diamonds 6 to 10 at the south pole.

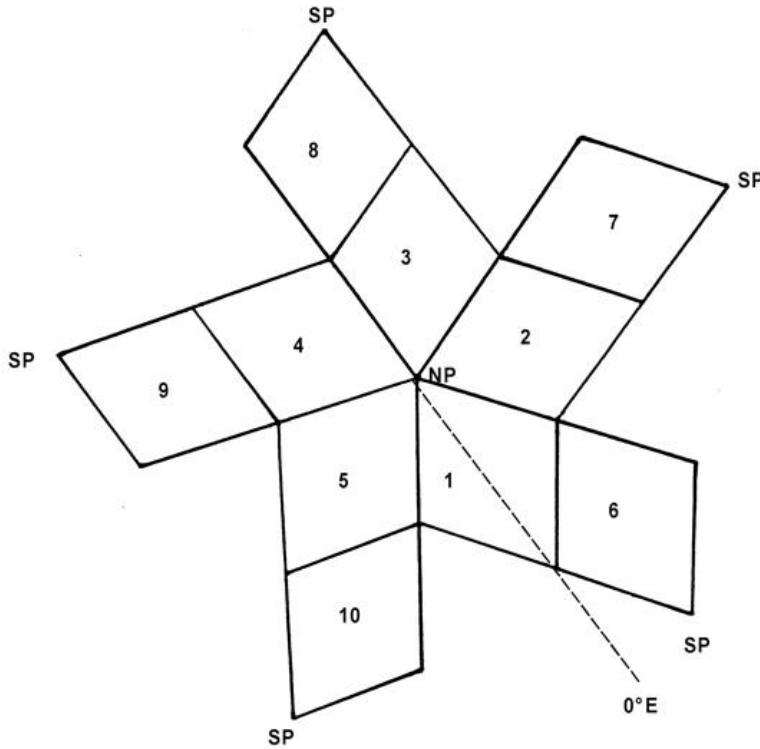

Fig. 1 Logical data structure of the icosahedral-hexagonal GME grid. It consists of ten diamonds, five of these contain the north pole, the other five the south pole.

The indexing of the *grid points* (Fig. 2) is based on the convention that those $n_i \times n_i$ grid points which belong to only one diamond, are numbered from 1 to n_i in the rows and columns of the square data array. The grid points at the eastern edges of the diamonds, $(0,1)$ to $(0, n_i+1)$ and $(0, n_i+1)$ to (n_i, n_i+1) are contained in two (some corner points in three) neighbouring diamonds, and their values have to be exchanged after each time step during the model run. The grid points at the poles $(0,1)$ are even contained in five diamonds. Diamonds 1 to 5 contain the north pole, diamonds 6 to 10 contain the south pole.

A GME-field **gme field** $(0:n_i, 1:n_i+1, 10)$ in the icosahedral-hexagonal model grid thus consists of $10 \cdot (n_i+1)^2 = 660490$ grid points for $n_i = 256$.

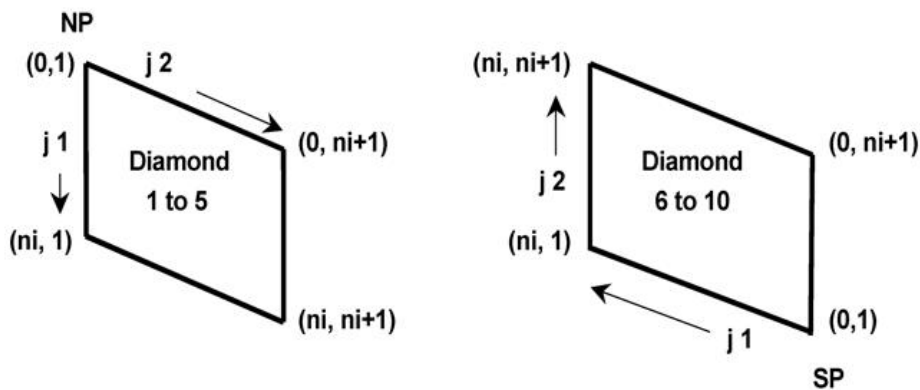

Fig. 2 Indexing of the grid points within a diamond; on the left for diamonds 1 to 5 which contain the north pole, and on the right for diamonds 6 to 10 which contain the south pole.

3. Vertical grid

The vertical discretization of GME is based on a hybrid coordinate system (sigma-pressure) after *Simmons and Burridge (1981)*. The pressure p_h at the layer interfaces (= half levels) is given by:

$$p_h(j1, j2, j3, jd) = ak(j3) + bk(j3)*ps(j1, j2, jd)$$

with $j3 = 1, i3e + 1$ where $i3e$ is the number of GME layers. ($i3e = 40$),
 ps time-dependent surface pressure on the orography of the model,
 $j1 = 0, ni$ row index,
 $j2 = 1, ni+1$ column index,
 $jd = 1, 10$ diamond index.

The pressure p_r at the center of the layer (= full levels), where most variables of the GME are defined, is given by the arithmetic mean of the pressure values at the adjacent half levels:

$$p_r(j1, j2, j3, jd) = 0.5*(p_h(j1, j2, j3, jd) + p_h(j1, j2, j3+1, jd))$$

with $j3 = 1, i3e$.

The vertical coordinate parameters ak and bk are stored in the Grid Description Section (GDS) of each GRIB1-Record; for the 60-layer version of the GME they have the following values (Tab. 3.1).

Table 3.1 The vertical coordinate parameters **ak** and **bk** of the GME (60-layer version)

K	ak (Pa)	bk (-)	K	ak (Pa)	bk (-)
1	0.0	0.00000	32	18970.0	0.28236
2	1000.0	0.00000	33	18366.6	0.31497
3	2000.0	0.00000	34	17676.2	0.34876
4	3000.0	0.00000	35	16907.7	0.38354
5	4000.0	0.00000	36	16070.4	0.41909
6	5000.0	0.00000	37	15172.8	0.45526
7	6000.0	0.00000	38	14227.4	0.49175
8	7000.0	0.00000	39	13244.6	0.52835
9	7998.4	0.00002	40	12235.5	0.56482
10	8990.0	0.00010	41	11211.0	0.60094
11	9969.2	0.00031	42	10182.2	0.63648
12	10930.6	0.00076	43	9159.9	0.67123
13	11875.7	0.00158	44	8154.6	0.70496
14	12805.4	0.00293	45	7176.4	0.73749
15	13722.0	0.00494	46	6234.6	0.76861
16	14620.0	0.00782	47	5338.5	0.79817
17	15493.2	0.01173	48	4495.9	0.82598
18	16331.1	0.01687	49	3714.3	0.85192
19	17122.8	0.02342	50	3000.0	0.87586
20	17855.2	0.03157	51	2357.9	0.89771
21	18516.6	0.04147	52	1792.5	0.91738
22	19094.8	0.05326	53	1306.5	0.93483
23	19579.7	0.06705	54	901.0	0.95005
24	19962.4	0.08290	55	575.6	0.96304
25	20236.3	0.10087	56	328.7	0.97384
26	20397.0	0.12094	57	156.6	0.98254
27	20441.8	0.14311	58	52.7	0.98927
28	20370.4	0.16731	59	6.6	0.99420
29	20183.6	0.19346	60	0.0	0.99763
30	19884.9	0.22145	61	0.0	1.00000
31	19478.5	0.25113			

Table 3.2 Pressure (hPa) and mean height (m) of the GME model layers (full levels) for the US-Standard-Atmosphere (US 1976)

K	p_r (hPa)	z_r (m)	K	p_r (hPa)	z_r (m)
1	5.00	35776	31	462.52	6145
2	15.00	28368	32	489.31	5734
3	25.00	25028	33	516.48	5335
4	35.00	22856	34	543.92	4949
5	45.00	21247	35	571.52	4576
6	55.00	19971	36	599.18	4217
7	65.00	18912	37	626.78	3872
8	75.00	18004	38	654.17	3541
9	85.00	17210	39	681.23	3225
10	95.00	16505	40	707.84	2925
11	105.04	15868	41	733.88	2639
12	115.22	15281	42	759.23	2369
13	125.69	14730	43	783.78	2114
14	136.62	14201	44	807.44	1874
15	148.18	13686	45	830.08	1650
16	160.47	13181	46	851.64	1442
17	173.61	12681	47	872.01	1248
18	187.68	12187	48	891.12	1070
19	202.75	11697	49	908.91	907
20	218.87	11212	55	925.32	759
21	236.05	10732	51	940.32	626
22	254.33	10252	52	953.87	506
23	273.68	9773	53	965.97	401
24	294.09	9297	54	976.60	310
25	315.54	8824	55	985.79	231
26	337.97	8357	56	993.58	165
27	361.33	7897	57	1000.02	111
28	385.55	7445	58	1005.17	67
29	410.55	7001	59	1009.15	34
30	436.24	6567	60	1012.05	10

Tab. 3.2 lists the pressure (in hPa) and mean height (in m) of the full levels of the GME for the US-Standard-Atmosphere. The lowest full level is about 10 m above the model orography, and the lowest model layer with a depth of about 20 m is defined as Prandtl layer (constant flux layer) in the turbulence parameterization. The uppermost full level is placed at 5 hPa.

4. Parallelisation of GME, 2D domain decomposition

Up to version 2.27 the 2D domain the $(n_i+1)^2$ grid points of each diamond are distributed to $n1 \times n2$ processors (processing elements, PEs).

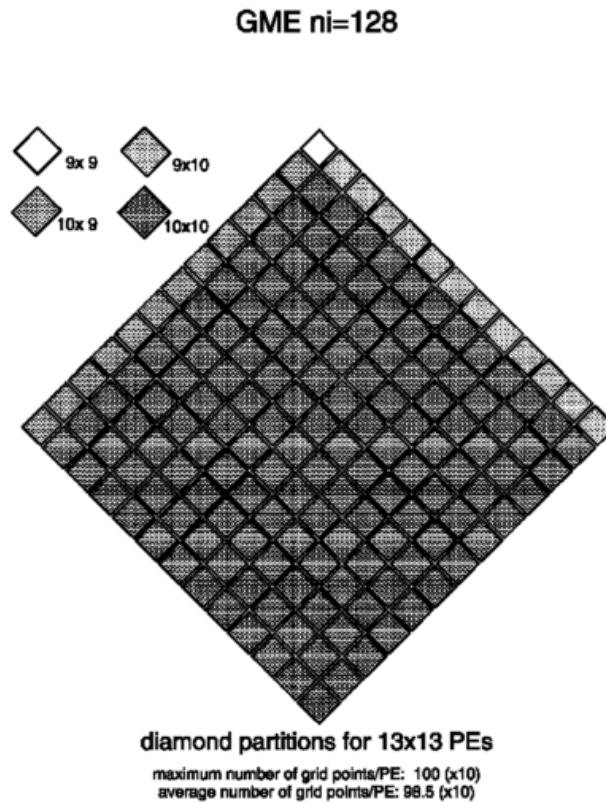

Fig. 3 2D domain decomposition of a diamond at $n_i = 128$ for 13×13 PEs.

Thus each PE computed the forecast for a sub-domain of each of the 10 diamonds. This yields a better load balance for the physical processes, e. g. in the radiation scheme between day and night or in the cloud microphysics between rain and no-rain areas. With 7×16 logical PEs (which are 7×8 physical PEs) on an IBM p575 the physical parameterizations need about 350s real time per forecast day. Each subdomain is surrounded by a *halo* of two rows and columns. These data have to be exchanged each time step between adjacent sub-domains. This communication is based on MPI (Message Passing Interface). During one complete forecast step there is a synchronization point in subroutine *progorg* where this communication is initiated.

To allow for a good load balance, each sub-domain should get approximately the same work load. Therefore the difference between the average number of grid points in a sub-domain and the maximum number should be as small as possible.

With **version 2.28** it is possible to distribute to $n1 \times n2 \times n3$ processors. Each processor gets subdomains from $10 / n3$ diamonds. Hence, $n3$ can be 1, 2, 5, or 10. Using $n3 > 1$ increases the ratio of inner points to boundary points of a region reducing the amount of data which must be exchanged between the processors.. In addition, on vector computers it allows to use longer vectors increasing $n3$ instead of $n1$ when many processors are used. On the NEC SX-9 at DWD the number of processors could be reduced from 3×40 to $1 \times 7 \times 10$, and the newer version is faster than the previous one. (A small speed-up comes from a new compiler version.)

5. Physical Parameterizations

Unresolved atmospheric processes interact with the large-scale flow but contain also essential forecast information (e. g. cloudiness or precipitation) which can not be generated by the adiabatic part of the model. The simulation of such processes in the GME is handled by a set of dedicated parameterization modules.

5.1. Radiation and clouds

Radiative transfer of solar and thermal radiation in clear and cloudy atmospheres is based on *Ritter and Geleyn (1992)*. A full radiation step is performed every hour at all grid points, solar fluxes are computed each time step taking the actual zenith angle into account but the atmospheric transmission from the previous full radiation step is used. The longwave cooling rate is kept constant during the one-hour period.

Cloudiness is derived from specific cloud liquid water and ice contents, relative humidity, convective activity and stability. If the cloud liquid water content q_c exceeds 0 (the grid box is then saturated with respect to water) the cloud cover is set to 1. In the case of cloud ice q_i thin cirrus clouds have to be taken into account, which are semi-transparent for small cloud ice contents. Thus for $q_i = 0.1$ mg/kg, the cloud cover is set to 0.3, for $q_i = 2$ mg/kg, the cloud cover is set to 0.56, and for $q_i = 20$ mg/kg, the cloud cover is set to 1.

In the case of $q_c = q_i = 0$ a partial cloud cover is derived which is based on an empirical relation using the relative humidity of the layer under consideration. In convective situations, i. e. if the convection scheme diagnosed a convective cloud, the depth of the convective cloud is also taken into account. If a stable layer exists at the layer of the convective cloud top the cloud cover is increased to simulate the formation of an anvil.

The computation of the high, medium and low cloud cover (CLCH, CLCM, CLCL) takes the cloud cover of each model layer (CLC_RAD) into account. If two adjacent model layers are cloudy, the total cloud cover is the maximum of the two layers (maximum overlap). If a cloud-free layer is in between, the total cloud cover will be higher than the cloud cover of the single layers (random overlap).

Radiation is computed in the subroutine *parrad*, cloudiness is computed in the subroutine *parcl*. The interval between two full radiation steps is controlled by the NAMELIST variables *hincrad_s* (solar) and *hincrad_t* (thermal) in */phy_ctl/*.

During the first forecast hour a full radiation step is performed every 15 minutes to allow for a better initial adaptation of the cloud field.

The heating rate due to solar radiation is stored in SOHR_RAD, the one due to thermal radiation in THHR_RAD. The solar radiation balance (average value since start of the forecast) at the top/bottom of the atmosphere is stored in ASOB_T/ASOB_S, the thermal radiation balance in ATHB_T/ATHB_S.

5.2. Grid-scale precipitation

For the parameterization of grid-scale precipitation GME has two cloud microphysics schemes with the five water species water vapour, cloud liquid water, cloud ice, and the precipitation phases rain and snow. These five phases interact in many ways (e. g. aggregation, deposition, riming, shedding; see Fig. 4) described by microphysical processes which are formulated depending on the mixing ratios of the different water phases. The operational model is based on the grid-scale precipitation scheme of the model COSMO-EU (Seifert,

2008; namelist parameter `ntype_gsp=2` or 3). All five species are calculated prognostically. Thus horizontal and vertical advection of rain and snow particles is taken into account, which is an important process for the proper simulation of the spatial structure of the precipitation field. This grid-scale precipitation is computed in the subroutine `prog_gsp`.

With mesh sizes of 40 km or greater the operational model employed a scheme where the precipitation phases rain and snow are treated diagnostically (Doms and Schättler, 2003; namelist parameter `ntype_gsp=1`). This grid-scale precipitation is computed in the subroutine `pargsp_qi`.

Grid-scale precipitation (rain and snow, accumulated since the start of the forecast) is stored in `RAIN_GSP` and `SNOW_GSP`.

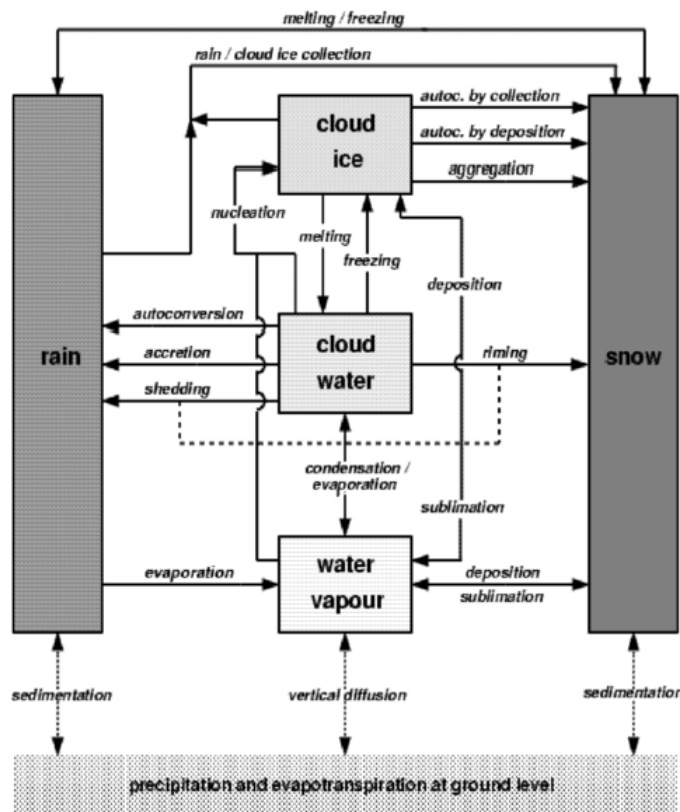

Fig. 4 Grid-scale parameterization scheme of the GME including cloud microphysics

5.3. Convection

The parameterization of deep and shallow convection is based on a mass flux approach (Tiedtke, 1989).

The convection scheme distinguishes three different convection types, namely shallow, mid-level and penetrative (deep). The three-dimensional convergence of water vapour is used as closure assumption for shallow and deep convection. Convective precipitation is initiated only if the cloud depth exceeds 300 hPa (~ 3000 m) over land and 150 hPa (~ 1000 m) over water.

The height of the base and top of convective clouds (above msl) is stored in the variables `HBAS_CON` and `HTOP_CON`. The convective precipitation (rain and snow, accumulated since the start of the forecast) is stored in `RAIN_CON` and `SNOW_CON`.

To save computing time, the convective parameterization is not computed each time step but only each *ninccon* time step (*ninccon* is defined in NAMELIST / *phy_ctl* /).

Convection is computed in the subroutine *parcon*.

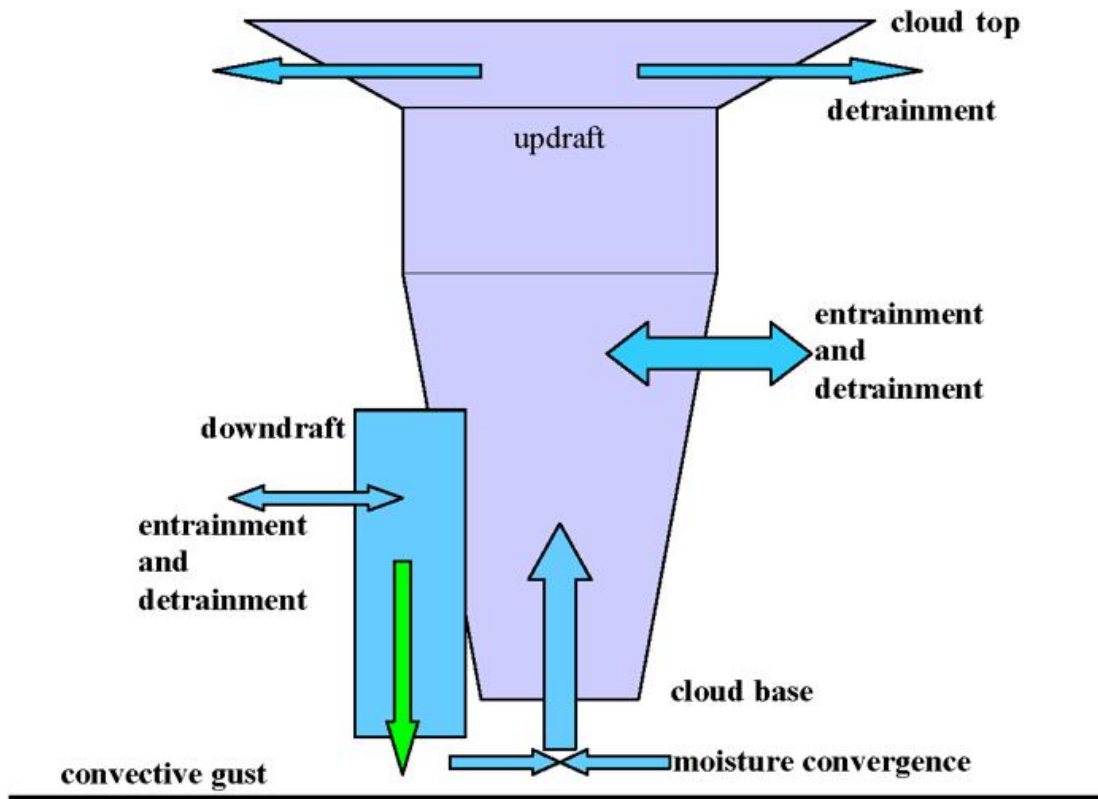

Fig. 5 Processes taken into account in the parameterization of convection in the GME

5.4. Turbulent fluxes in the ABL and the free atmosphere

The parameterization of the vertical turbulent fluxes (*Müller*, 1981) is based on *Louis* (1979) in the Prandtl-layer (which is the layer closest to the surface) and a diagnostic level-two scheme based on *Mellor and Yamada* (1974) for the boundary layer and the free atmosphere.

Transfer coefficients for momentum, heat and moisture (and the roughness length over sea) at the surface are computed in the subroutine *parturs*, diffusion coefficients for momentum, heat and moisture are computed in the subroutine *partura*.

To save computing time, the calculation of turbulent diffusion coefficients in the atmosphere is not computed each time step but only each *ninctura* time step (in NAMELIST / *phy_ctl* /).

The transfer coefficient for momentum is stored in TCM, the one for heat and moisture in TCH.

The turbulent diffusion coefficient for momentum is stored in TKVM, the one for heat and moisture in TKVH.

5.5. Soil model

The multi-layer soil model (*Heise and Schrodin, 2002*) comprises seven active layers for the heat (energy) and six for the soil moisture (water) budget.

Prognostic variables are soil temperature, total (liquid and frozen) soil water content and the soil ice content. Additionally, a snow cover is described by a water content of snow, a mean snow density and a snow “freshness” factor which is used in the computation of the solar albedo. Finally, a small amount of water can be stored in the interception storage.

Soil temperatures are defined at nine levels: 0, 0.5, 2, 6, 18, 54, 162, 486 and 1458 cm in the ground. The temperature at the interface soil – atmosphere is identical to the one at a depth of 0.5 cm. The temperature at a depth of 1458 cm is constant and taken from climatological values of annual mean temperature at 2 m.

Soil moisture is calculated for the six active layers 0 – 1, 1 – 3, 3 – 9, 9 – 27, 27 – 81, 81 – 243 while for the layers 243 – 729 and 729 – 2187 cm it is kept constant.

The soil model is split into two parts *parsoil_a* and *parsoil_b*.

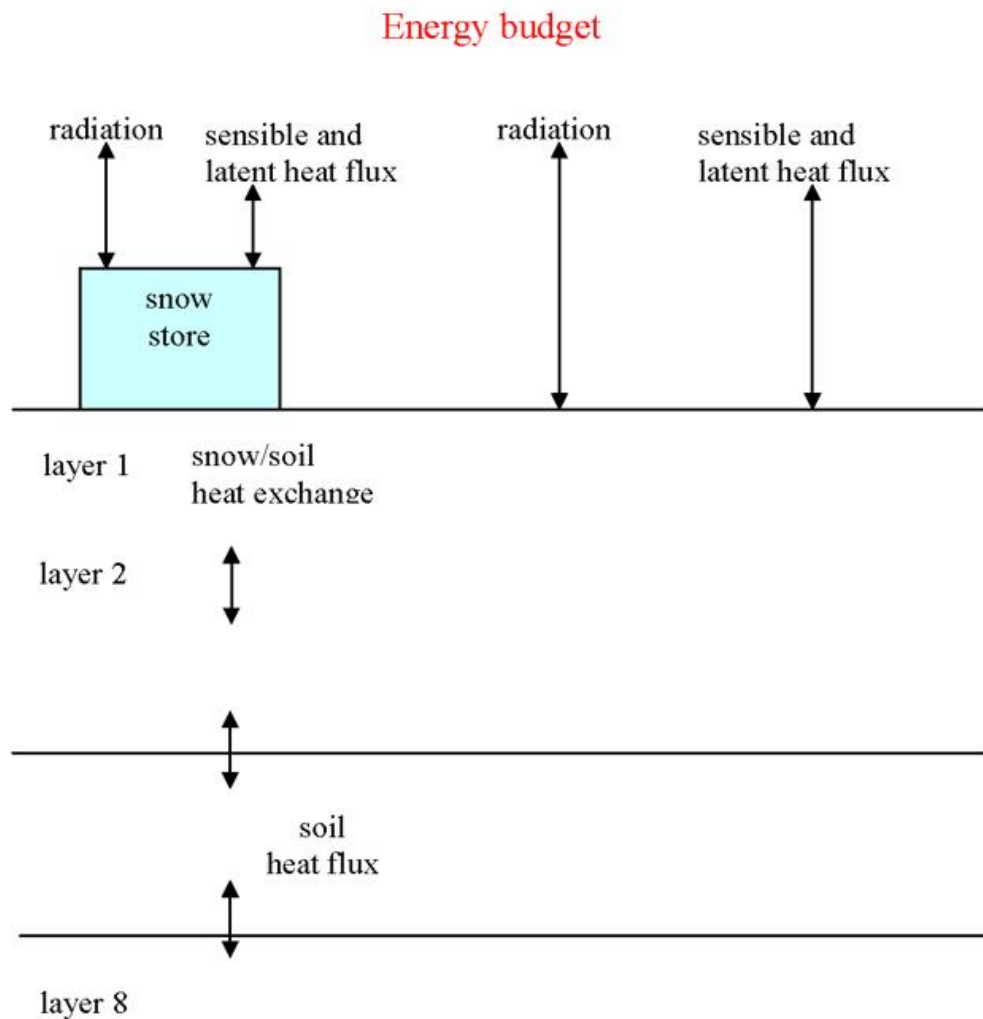

Fig. 6 Processes taken into account in the thermal part of the GME soil model

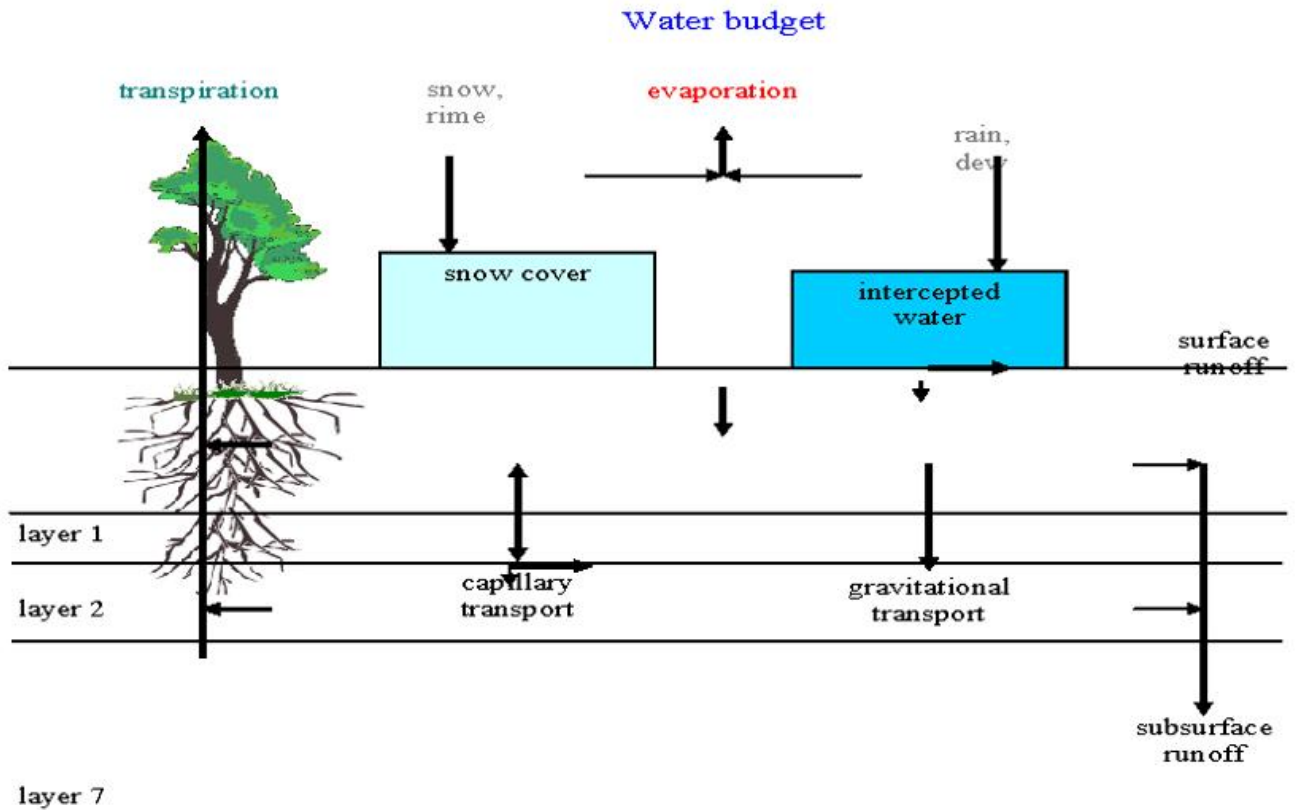

Fig. 7 Processes taken into account in the hydrological part of the GME soil model

The temperature at the surface of a snow cover is stored in T_SNOW ; the temperature at the interface surface – atmosphere or surface – bottom of snow cover is stored in T_S . The temperature at the interface surface – atmosphere is stored in T_G ; for land points without snow and water points $T_S = T_SNOW = T_G$. The soil temperature is stored in T_SO .

The water content of the snow cover is stored in W_SNOW , the snow density in RHO_SNOW , the snow freshness factor in $FRESHSNW$.

The total soil water is stored in W_SO , the frozen part in W_SO_ICE . Intercepted water is stored in W_I .

The vegetation is characterized by plant cover ($PLCOV$), leaf area index (LAI) and root depth ($ROOTDP$). Actual values of $PLCOV$ and LAI are derived from maximum values

interface surface - atmosphere or surface - bottom of snow cover is stored in T_S . The temperature at the interface surface - atmosphere is stored in T_G ; for land points without snow and water points $T_S = T_SNOW = T_G$. The soil temperature is stored in T_SO .

The water content of the snow cover is stored in W_SNOW , the snow density in RHO_SNOW , the snow freshness factor in $FRESHSNW$.

The total soil water is stored in W_SO , the frozen part in W_SO_ICE . Intercepted water is stored in W_I .

The Vegetation is characterized by plant cover ($PLCOV$), leaf area index (LAI) and root depth ($ROOTDP$). Actual values of $PLCOV$ and LAI are derived from maximum values

PLCOV_MX and LAI_MX scaled by the NDVI ratio which is based on monthly climatological values and updated daily during the forecast.

ATTENTION: The temporal integration of the soil model is based on a 2-time level scheme with the time levels “ $t-\Delta t$ ” (nt2m) and “ t ” (nt2c), while the rest of the model is integrated by a 3-time level scheme with the time levels “ $t-\Delta t$ ” (nt3m), “ t ” (nt3c) and “ $t+\Delta t$ ” (nt3p).

5.6. SSO scheme

Subgrid-scale orographic variability has a pronounced impact on the mean (resolved) flow of GME. Within one model grid box there are height differences in the order of several hundreds of meters in many mountainous regions. Thus the mean orography alone does not fully describe the influence of the mountains on the atmosphere. Subgrid-scale orographic features can block on one hand the flow in the lowest model layers and on other hand give rise to gravity wave which break and dissipate higher up retarding the flow in the middle and upper troposphere. GME uses a subgrid-scale orography (SSO) scheme developed by *Lott and Miller (1997)*. The scheme takes into account not only the subgrid-scale variability of orography (via the standard deviation of height) but the orientation, steepness and horizontal anisotropy of the subgrid-scale orographic structures. These parameters can be derived from the 1 km² global GLOBE orography data set.

To save computing time, the SSO scheme is not called each time step but only each *nincso* time step (in NAMELIST / *phy_ctl* /).

5.7. Sea ice model

The sea ice model (*Mironov and Ritter, 2003; Mironov and Ritter, 2004*) computes the thermodynamical effects of an oceanic ice layer. The heat conduction through the ice layer is parameterized via a bulk approach where the form of the temperature profile in the ice layer is prescribed but variable with time. There are two prognostic variables, namely the temperature at the sea ice – air interface and the ice thickness. Currently, a snow cover on the sea ice layer is not taken care of. Ice cover *FR_ICE* (either 1 or 0, no fractional ice cover) is taken once per day (at 00 UTC) from observations during the SST analysis. New grid boxes with sea ice are assigned an ice thickness of 0.5 m. The maximum ice thickness is set to 3 m. The sea ice model can melt existing ice (by setting *FR_ICE* to 0) but cannot form new ice.

6. Initial state

The **initial state** of the GME is prepared by the data assimilation scheme which consists of the

- a) 3D-Var-analysis (PSAS: Physical Space Assimilation System) of surface pressure, temperature, humidity (relative humidity) and horizontal wind components,
- b) snow analysis scheme,
- c) analysis of sea surface temperature (SST), performed once a day at 00 UTC.
- d) analysis of sea ice fraction (*FR_ICE*), performed once a day at 00 UTC.

The analyses valid at 00, 06, 12 and 18 UTC are prepared once with a short data cut-off of 2h 14min to serve as initial states of GME forecasts up to 174h (from 00 and 12 UTC) and 48h (from 06 and 18 UTC), and a second time with a much longer data cut-off for data assimilation purposes.

7. Initialization

To remove high frequency initial noise from the forecast GME employs a diabatic (incremental) digital filtering initialization (DFI; Lynch, 1997) which includes a short forecast of the GME with full physics (except the soil model). The DFI consists of an adiabatic backward integration over the time range *tspan* (in NAMELIST / dfi_ctl /; normally set to $5.400 \text{ s} = 1.5$ hours) and a diabatic forward integration over the same period. The prognostic variables (surface pressure, wind components and temperature) are filtered during these integrations to remove high-frequency oscillations. The humidity fields (relative humidity, cloud liquid water and cloud ice) and ozone are kept unchanged during the initialization.

To reduce the impact of the DFI on the initial state, the filtering is performed in vertical normal mode space; the number of vertical modes filtered is controlled via the variable *nvmdfi* (in NAMELIST / dfi_ctl /). Setting e.g. *nvmdfi* = 15 for a 60-layer GME (*i3e* = 60), only the external and the first 14 internal modes are filtered by the DFI, the higher 45 (16 to 60) modes are left unchanged. Thus the structure of the atmospheric boundary layer will hardly be changed by the DFI.

In data assimilation mode it is not advisable to perform a full DFI after each analysis step because the DFI could damp the meteorological pattern in the whole model domain even in those regions where the model first guess (FG, i.e. the 3-h GME forecast valid at analysis time) was not altered by the analysis scheme. In this case the *incremental* DFI (IDFI) offers a better solution. For the IDFI the initialized FG (FG(DFI)) is subtracted from the initialized analysis (ANA(DFI)) and this difference is added to the FG.

$$\text{ANA (IDFI)} = \text{ANA (DFI)} - \text{FG (DFI)} + \text{FG}$$

The IDFI modifies the analysis only in those regions where the balanced state of the first guess fields has been modified due to the input of observations.

After the analyses valid at 00, 06, 12 and 18 UTC, an IDFI is performed while no initialization is necessary for the analyses valid at 03, 09, 15 and 21 UTC because there are less upper air data which might disrupt the delicate balance between mass and wind field in the GME first guess fields.

8. NAMELIST Input of GME

8.1. Introduction

The runtime control parameters of GME are contained in an ASCII file called **INPUT_GME** in the form of NAMELIST variables. These variables are split into eight different NAMELIST groups which have to appear in the following order in the file **INPUT_GME**:

- &gme_ctl** - general control variables and switches mostly contained in COMMON block / gme_comorg /
- &dyn_ctl** - control variables and switches for the dynamics of the model, contained in COMMON block / gme_comdyn /
- &dfi_ctl** - control variables and switches for the digital filtering initialization, contained in COMMON block / gme_comdfi /
- &phy_ctl** - control variables and switches for the physics of GME, contained in COMMON block / gme_comphy /
- &dia_ctl** - control variables and switches for the diagnostics of GME, contained in COMMON block / gme_comdia /
- &met_ctl** - control variables and switches for meteographs of GME, contained in COMMON block / gme_comgpmet /
- &gribin** - control variables and switches for the input of the initial data (analysis), contained in COMMON block / gme_comio /
or **alternatively** (if the NAMELIST variable *lartif_data* in **&gme_ctl** is set to .true.)
- &artif_ctl** - control variables and switches for the definition of test cases contained in COMMON block / gme_comartif /
- &gribout** - control variables and switches for the post-processing of GME, i.e. the creation of GRIB output files. The control variables and switches are contained in COMMON block / gme_comio /

The last NAMELIST group **&gribout** can occur several times. Each group may define a different list of variables for GRIB output, different time steps and/or different grids. If no GRIB output is required, this group can be omitted altogether.

Also NAMELIST group **&met_ctl** can occur several times.

For test cases with artificial initial data (in this case the NAMELIST variable *lartif_data* in group **&gme_ctl** is set to .true.) the NAMELIST group **&gribin** has to be replaced by the group **&artif_ctl**.

8.2. Example of INPUT_GME file

An example of an INPUT_GME file is given here:

```
# Namelist Input Control file (INPUT_GME)
#
&gme_ctl
  ydate_ini='2010102300',
  ni=256, i3e=60, hstop=174., nproc1=1, nproc2=20, nproc4=2,
  hincmxm=3., lprog_o3=.true.,
/
&dyn_ctl
  dt=100., lsits=.true., asi=1.4, bsi=1.4, epsass=0.15, rkh4=2.0e13,
  rkh2=3.0e5, fkh2_q=0.2, fkh2_t=2.0, fkh2_w=1.0, fkh4_q=0.2, fkh4_t=2.0,
  fkh4_w=1.0,
/
&dfi_ctl
  ldfi_nstart=.true., ndfi=2, taus=10800., tspan=5400., dtbak=90.,
  dtfwd=90., hinc_fg=3., nvmdfi=10, lhdiff=.true., ldfi_incr=.true.,
  hinc_fg=3.,
/
&phy_ctl
  lphys=.true., lrad=.true., ntype_gsp=2, lsea_ice=.true.,
  lcon=.true., ltur=.true., lsoil=.true., lssso=.true.,
  hincrad_s=1., hincrad_t=1., ninctura=3, nincon=5, ninssso=3,
/
&dia_ctl
  hincdia=24.,
  hincctl=1.,
/
&met_ctl
  ngpmet=1, ynamegp='Frankfurt', zlongpmet=8.58, zlatgpmet=50.05,
  hincmet=3., ymettype='short',
/
&gribin
  yanadir='/uwork0/for3maj/gme_256/ana/',
  yfgdir='/uwork0/for3maj/gme_256/fg/',
  yform_read='apix',
/
&gribout
  ngrib=0, lpp_ini=.true.,
  ysystem='file',
  ydir='/uwork0/for3maj/gme_256/fct/',
  yvarpl='T', 'FI', 'U', 'V', 'PS', 'RELHUM', 'OMEGA',
  yvarml='FIS', 'FR_LAND',
  lreg=.true., rinclon=0.25, rinclat=0.25,
  lcheck=.false.,
/
&gribout
  hcomb=6., 174., 6.,
  ysystem='file', yform_write='apil',
  ydir='/uwork0/for3maj/gme_192/fct/',
  yvarml='T_G', 'T_2M', 'ASOB_S', 'ATHE_S', 'ASOB_T', 'ATHE_T',
  'RAIN_GSP', 'SNOW_GSP', 'RAIN_CON', 'SNOW_CON',
  'CLCH', 'CLCM', 'CLCL', 'CLCT',
  'ASHFL_S', 'ALHFL_S',
  'U_10M', 'V_10M', 'TD_2M',
  'U', 'V', 'T', 'BAS_CON', 'TOP_CON', 'PS',
  yvarpl='T', 'FI', 'U', 'V', 'PS', 'RELHUM', 'OMEGA',
  lreg=.true., rinclon=0.25, rinclat=0.25,
  lcheck=.false.,
/
```

8.3. Explanation of the different control variables and switches

8.3.1. &gme_ctl - General control variables and switches

Parameter	Type	Meaning of Parameter	Default
ni	INT	Resolution of GME, i.e. the number of intervals on a main triangle side; <i>ni</i> must be of the form $ni = 3^{ni3} * 2^{ni2}$, where $ni3 = 0$ or 1 and $ni2$ integer.	192
i3e	INT	Number of model layers; the number of model levels (layer interfaces) is $i3e + 1$.	40
i3e_soil	INT	Number of active soil model layers; layer $i3e_soil+1$ is considered as climate layer.	7
ydate_ini	CH*10	Initial date of the forecast in the form <code>yyyymmddgg</code> , where yyyy: year, e.g. 1999 mm: month, e.g. 06 dd: day, e.g. 25 gg: time, e.g. 18 (UTC)	' '
nproc1	INT	Number of processors used in j1-direction on MPP machines (e.g. IBM p575). For message passing, MPI (Message Passing Interface) is used.	1
nproc2	INT	Same as <i>nproc1</i> , but for j2-direction; with <i>nproc1</i> and <i>nproc2</i> the usual 2-D domain decomposition is performed on a diamond. The $(ni + 1)^2$ grid points of a diamond are divided among the $nproc1*nproc2$ processing elements (PEs). Each PE holds data of $10/nproc4$ diamonds.	1
nproc4	INT	Same as <i>nproc1</i> , but for the diamonds. Values 1,2,5, or 10 a possible. Each PE holds data of $10/nproc4$ diamonds.	1
nstart	INT	Number of first time step; if $nstart > 0$ and $nstop > nstart$, GME is in restart mode, i.e. it requires data of two consecutive time levels (t, t-Δt) to resume a forecast. If $nstart = nstop > 0$, GME is in run in post-processing mode, i.e. performing no real forecast. Alternatively:	0
hstart	REAL	Same as <i>nstart</i> , but time in hours	0.
nstop	INT	Number of last time step to be performed; Alternatively:	-1
hstop	REAL	Same as <i>nstop</i> , but time in hours	-1.
nincmxm	INT	Interval in time steps for the validity of maximum and minimum values, i.e. every <i>nincmxm</i> time steps the relevant arrays are reset to default values. Alternatively:	0
hincmxm	REAL	Same as <i>nincmxm</i> , but time in hours	6.

Parameter	Type	Meaning of Parameter	Default
ytrans	CH*128	Name of directory for 'ready' files. These files are used to tell other jobs which are using GRIB files of the GME during the model run that a specific forecast step has been completed by GME and the corresponding GRIB files are ready. No 'ready' files are written if ytrans is an empty string.	
ldebug	LOGICAL	Debug switch, if .true. GME will print quite a lot of debug information. For version 2.12 or higher use ldebug_xxx and idbg_level (see below)	.false.
lprog_o3	LOGICAL	Ozone (o3) switch; if .true. use prognostic ozone (as passive tracer only, no ozone chemistry). The initial values of o3 have to be in the initial data file.	.false.
hstop_o3	REAL	Stop running with ozone (o3) advection after more than hstop_o3 hours forecast time.	9999.
lana_rho_snow	LOGICAL	Switch to indicate if snow density should be read from the initial file.	.true.
qvmin	REAL	Minimum value of water vapour qv; if qv less than qvmin, qv = qvmin; security parameter.	1.e-12
qcmin	REAL	Minimum value of cloud water content qc; if qc < qcmin, qc = 0; security parameter.	1.e-12
qimin	REAL	Minimum value of cloud ice content qi; if qi < qimin, qi = 0; security parameter.	1.e-12
qrmin	REAL	Minimum value of rain water content qr; if qr < qrmin, qr = 0; security parameter.	1.e-12
qsmin	REAL	Minimum value of snow content qs; if qs < qsmin, qs = 0; security parameter.	1.e-12
o3min	REAL	Minimum value of ozone mixing ratio o3; if o3 < o3min, o3 = 0; security parameter.	1.e-20
lana_qrqs	LOGICAL	Switch to indicate if qr and qs are give in the initial data file	.false.
l_date_grib_act	LOGICAL	Write actual creation date in output GRIB file, if .false., then two identical files are comparable with 'cmp'.	.true.
experiment_ID	CH*16	String to write experiment information in output file OUTPUT_GME	' '
lasync_io	LOGICAL	Asynchronous IO switch; if .true. 'nprocio' additional PE's for IO are used.	.false.
nprocio	INT	Number of additional PE's used for asynchronous IO.	0
nday_sst	INT	Time (steps) of update of sea surface temperature (for seasonal runs; 0: no update; 1: update every day; 2: update every other day).	0
ygen_ten	CH*4	Calculate averaged general tendencies. Possible values 'NONE', 'SSO'	'NONE'

Parameter	Type	Meaning of Parameter	Default
idbg_level	INT	Debugging level to control amount of output for different parts which are selected by ldebug xxx	0
ldebug_dyn	LOGICAL	Debug dynamics of GME	.false.
ldebug_si	LOGICAL	Debug semi-implicit time stepping	.false.
ldebug_gsp	LOGICAL	Debug grid scale precipitation scheme	.false.
ldebug_rad	LOGICAL	Debug radiation scheme	.false.
ldebug_tur	LOGICAL	Debug turbulence scheme	.false.
ldebug_con	LOGICAL	Debug convection scheme	.false.
ldebug_clc	LOGICAL	Debug sub-grid scale cloudiness scheme	.false.
ldebug_soi	LOGICAL	Debug soil model	.false.
ldebug_sso	LOGICAL	Debug SSO scheme	.false.
ldebug_ice	LOGICAL	Debug sea ice model	.false.
ldebug_io	LOGICAL	Debug IO part	.false.
ldebug_dia	LOGICAL	Debug diagnostic calculations	.false.
lartif_data	LOGICAL	If .true., run idealized test case; then the NAMELIST group &gribin has to be replaced by the group &artif_ctl	.false.
iepstyp	INTEGER	EPS member type	-1
iepstot	INTEGER	Total number of EPS members	-1
iepsmem	INTEGER	EPS member number	-1

8.3.2. &dyn_ctl - Control variables and switches for the dynamics of GME

Parameter	Type	Meaning of Parameter	Default
dt	REAL	Time step (in seconds)	133.33
rkh4	REAL	Diffusion coefficient (linear fourth order, unit: m^4/s)	0.
fkh4_w	REAL	Scaling of diffusion coefficient for wind	1.
fkh4_t	REAL	Scaling of diffusion coefficient for temperature	1.
fkh4_q	REAL	Scaling of diffusion coefficient for specific humidity	0.2
rkh2	REAL	Diffusion coefficient (linear 2. order, units: m^2/s) If $rkh2 > 0$, second order horizontal diffusion will be applied with increasing weight towards the model top in the stratosphere (model layers between 200 and 0 hPa). This diffusion damps smaller scale structures in the stratosphere effectively and helps to avoid a model crash due to CFL-violation in case of strong polar night jets.	0.
fkh2_w	REAL	Scaling of diffusion coefficient for wind	1.
fkh2_t	REAL	Scaling of diffusion coefficient for temperature	1.
fkh2_q	REAL	Scaling of diffusion coefficient for specific humidity	0.2
lsits	LOGICAL	Logical switch for semi-implicit (SI) time stepping; if .true., perform SI time stepping.	.true.
ldry	LOGICAL	Logical switch for dry forecast: if .true., perform dry forecast, i.e. set water vapour and cloud water and cloud ice contents to 0.	.false.
asi	REAL	Weight of implicitity of mass field in SI scheme; the $(t+\Delta t)$ values are weighted by $asi/2$, the $(t-\Delta t)$ values are weighted by $1-asi/2$ in the SI scheme; $asi > 1$ is necessary for stability reasons since it damps the gravity waves.	1.4
bsi	REAL	Same as <i>asi</i> , but for wind field	1.4
epsass	REAL	Asselin time filter coefficient; the Asselin filter ties the three time levels $(t-\Delta t)$, t , $(t+\Delta t)$ of the leap frog time integration scheme together.	0.15
nsi	INT	Number of 2-d Helmholtz equations solved in the split semi-implicit scheme	5
lray	LOGICAL	Logical switch for Rayleigh friction	.true.
i3e_ray	INT	Lowest vertical layer for which Rayleigh friction will be applied; this friction is applied only close to the model top in case of wind speeds near the CFL limit.	4
lmass_corr	LOGICAL	Do a posteriori mass correction after each time step. Note: Because this method requires the calculation of global sums the results of forecasts are not independent of the domain decomposition	.false.

Parameter	Type	Meaning of Parameter	Default
ltarg_dif	LOGICAL	Targeted smoothing of humidity switch; if .true. qv will be smoothed at those grid columns (above the boundary layer) where the vertical velocity exceeds the threshold value <i>om_min</i> . Target smoothing prevents the development of “grid point storms” in GME.	.true.
om_min	REAL	Minimum vertical velocity (dp/dt) at a layer of about 600 hPa to initiate targeted smoothing. If the vertical velocity is smaller than <i>om_min</i> , the specific humidity qv at t + Δt in this column is being smoothed from layers $j3 = 1$ to $j3 = 11800$ (a layer around 800 hPa for ps = 1000 hPa).	-2.0
cenwgt	REAL	Centre point weight of target smoothing which takes the 18 surrounding grid points into account. For cenwgt=0.1 the weight of point 0 is 0.2350, for the surrounding points 1 to 6 it is 0.0600, for the points 7, 9, ..., 17 it is 0.0450 and for the points 8, 10, ..., 18 it is 0.0225.	0.1

The following table gives an overview of suitable time steps (Δt , in sec) and coefficients for the linear fourth order (rkh4, in m^4/s) and second order (rkh2, in m^2/s) diffusion scheme at different resolutions (n_i , and grid spacing Δ , in km) of GME.

n_i	Δ (km)	Δt (sec)	rkh4 (m^4/s)	rkh2 (m^2/s)
32	240	900.000	8.00e15	0.80e6
48	160	600.000	3.25e15	0.60e6
64	120	400.000	1.00e15	0.40e6
96	80	257.143	4.00e14	0.30e6
128	60	200.000	1.25e14	0.20e6
192	40	133.333	0.50e14	0.25e6
256	30	100.000	0.20e14	0.30e6
384	20	66.667	0.50e13	0.13e6
512	15	50.000	0.30e13	0.10e6
768	10	33.333	0.10e13	0.10e6

8.3.3. &dfi_ctl - Control variables and switches for the Digital Filtering Initialization

Parameter	Type	Meaning of Parameter	Default
ldfi_nstart	LOGICAL	Logical switch, if .true., perform a DFI prior to the forecast.	.false.
ldfi_nstop	LOGICAL	Logical switch, if .true., perform a DFI at the end the forecast. (necessary at the end of the first guess run for the incremental DFI , so called IDFI)	.false.
ldfi_incr	LOGICAL	Logical switch, if .true., perform an IDFI prior to the forecast	.false.
ydate_fg	CH*10	Date of first guess (only for IDFI)	<i>hinc_fg</i> before <i>ydate_ini</i>
ninc_fg	INT	Forecast time in time steps of first guess (only for IDFI)	0
hinc_fg	REAL	Same as <i>ninc_fg</i> , but time in hours	3.
ndfi	INT	Indicator for method of DFI <i>ndfi</i> = 0: No filtering <i>ndfi</i> = 1: Launching (only forward stage) <i>ndfi</i> = 2: Full two-stage DFI (backward and forward)	0
nfilt	INT	Indicator for method of filtering <i>nfilt</i> = 1: Dolph-Chebyshev filter; no other filter implemented yet.	1
nvmdfi	INT	Number of vertical modes to be filtered of the prognostic variables t, u and v. The humidity variables (qv, qc, optionally qi) are kept at their initial values	15
tspan	REAL	Time-span (in seconds) for the adiabatic backward and diabatic forward stages of DFI	10800.
taus	REAL	Cut-off period (in seconds) for the DFI filter; <i>taus</i> is the stop-band edge of the Dolph filter.	10800.
dtbak	REAL	Time step (in seconds) for backward (hind-cast) filtering stage	Dt
dtfwd	REAL	Time step (in seconds) for forward (forecast) filtering stage; if <i>dtbak</i> and <i>dtfwd</i> are not set, the model time step <i>dt</i> defined in NAM-ELIST group / <i>dyn_ctl</i> / will be used.	Dt
lhdiff	LOGICAL	Logical switch, if .true., run the backward stage of DFI with horizontal diffusion; in this case, the diffusion coefficient will reverse its sign.	.false.
lepsass	LOGICAL	Logical switch, if .true., run the backward stage of DFI with Asselin time filter; the filter coefficient remains the same	.false.

8.3.4. &phy_ctl - Control variables and switches for the physical parameterizations

Parameter	Type	Meaning of Parameter	Default
lphys	LOGICAL	Logical switch, if .true., run with physical parameterizations. If .false., no physical parameterizations will be computed, but grid-scale condensation/evaporation is included assuming 100% relative humidity over water inside of clouds. To suppress this calculation, too, set <i>ldry</i> = .true. in NAMELIST group / dyn_ctl /.	.true.
lrad	LOGICAL	Logical switch, if .true., run with the radiation scheme which computes heating rates in the atmosphere (solar and thermal) and the energy balance (solar and thermal) at the ground. To save computing time, radiation will be called at certain intervals defined by the following four control variables:	.true.
nincrad_s	INT	Interval (in time steps) between two complete solar radiation computations; Alternatively:	0
hincrad_s	REAL	Interval (in hours) between two complete solar radiation computations. An interval of one or two hours yields sufficient accuracy.	1.
nincrad_t	INT	Interval (in time steps) between two complete thermal radiation computations; Alternatively:	0
hincrad_t	REAL	Interval (in hours) between two complete thermal radiation computations. An interval of one or two hours yields sufficient accuracy.	1.
ntype_gsp	INT	Switch for type of grid scale precipitation scheme; currently four options available: 0: grid scale precipitation switched off 1: Diagnostic grid scale precipitation (subroutine pargsp_qi) 2: Prognostic grid scale precipitation (subroutine micro_physics), no advection of qr and qs 3: Prognostic grid scale precipitation (subroutine micro_physics), with advection of qr and qs	1

Parameter	Type	Meaning of Parameter	Default
lcon	LOGICAL	Logical switch, if .true., run with moist convection (Tiedtke's mass flux scheme) which computes the effect of moist convection on temperature, water vapour and winds in the atmosphere as well as the rates of convective rain and snow fall at the ground. To save computing time, moist convection may not be called each time step, but at certain intervals defined by the following variable:	.true.
ninccon	INT	Interval (in time steps) between two calls of the moist convection parameterization scheme. <i>ninccon</i> should be an odd number to avoid using the same time family all the time. <i>ninccon</i> = 3 or 5 yields sufficient accuracy.	5
ltur	LOGICAL	Logical switch, if .true., run with the turbulence (vertical diffusion) scheme which computes exchange coefficients in the atmosphere (different coefficients for temperature/water substances and momentum) and the transfer coefficients at the ground (Prandtl layer). Over water, the roughness length z_0 is computed, too. To save computing time, the exchange coefficients in the atmosphere may not be computed each time step but at certain intervals defined by the following control variable:	.true.
ninctura	INT	Interval (in time steps) between two calls of the computation of vertical exchange coefficients. <i>ninctura</i> should be an odd number to avoid using the same time family all the time. <i>ninctura</i> = 3 or 5 yields sufficient accuracy.	5
lsoil	LOGICAL	Logical switch, if .true., run with the multi-layer soil parameterization scheme. Over water, the sea surface temperature (SST) is kept constant during the integration (if it is not updated via <i>nday_sst</i> in <i>/gme_ctl/</i>).	.true.
lmelt_soil	LOGICAL	On/off-switch to include melting/freezing in soil scheme	.true.
lmelt_soil_var	LOGICAL	On/off-switch to consider water content dependency of melting/freezing temperature	.true.
nsoil_moist	INT	Soil layer with artificial setting of moisture content	0
ntype_trvg	INT	Type of vegetation transpiration parameterization	2
ntype_evsl	INT	Type of parameterization of bare soil evaporation	2
lso	LOGICAL	Logical switch, if .true., run with the subgrid-scale orography parameterization.	.true.

Parameter	Type	Meaning of Parameter	Default
		To save computing time, the subgrid-scale orography parameterization may not be called each time step but at certain intervals defined by the following control variable:	
nincssso	INT	Interval (in time steps) between two calls of the subgrid-scale orography parameterization. <i>nincssso</i> should be an odd number to avoid using the same time family all the time. <i>nincssso</i> = 3 or 5 yields sufficient accuracy.	5
lsea_ice	LOGICAL	Logical switch, if .true. run with sea ice model.	.false.
lz0_snow	LOGICAL	Logical switch, if .true. run with separate scalar roughness length for snow covered surfaces.(Still under development!)	.false.

8.3.5. &dia_ctl - Control variables and switches for diagnostics

As of now, two types of diagnostics have been implemented in GME, namely **dia** and **ctl**.

dia computes mean values of all prognostic variables (plus some derived quantities) for the global domain (land **and** water points) and for land and water separately. Multi-level fields are given on each model level. The results are written to an ASCII file named **DIAGNOSTICS**.

ctl computes control variables, mostly global mean values of quantities like surface pressure, surface pressure tendency, kinetic energy, maximum wind speed, cloud cover or precipitation rates, which allow a quick-look control of the model run. The results are written to an ASCII file named **OUTPUT_GME**.

Parameter	Type	Meaning of Parameter	Default
nstartdia	INT	Number of first diagnostic step; If <i>nstartdia</i> > <i>nstop</i> , no diagnostics will be performed. Alternatively:	0
hstartdia	REAL	Same as <i>nstartdia</i> , but in hours	0.
nincdia	INT	Interval (in time steps) between two calls of the diagnostic calculations; if <i>nincdia</i> = 0, no diagnostics will be performed. Alternatively:	0
hincdia	REAL	Interval (in hours) between two calls of the diagnostic calculations; if <i>hincdia</i> = 0., no diagnostics will be performed.	24.
nstartctl	INT	Number of first control output step; If <i>nstartctl</i> > <i>nstop</i> , no control output will be computed. Alternatively:	0
hstartctl	REAL	Same as <i>nstartctl</i> , but in hours	0.
nincctl	INT	Interval (in time steps) between two calls of the control calculations; if <i>nincctl</i> = 0, no control output will be computed. Alternatively:	0
hincctl	INT	Interval (in hours) between two calls of the control calculations; if <i>hincctl</i> = 0., no control output will be computed.	1.
lpr_id	LOGICAL	Logical switch, if <i>.true.</i> , check the initial data, i.e. print some information like maximum and minimum values of each input field.	<i>.true.</i>

8.3.6. &met_ctl - Control variables and switches for meteographs

As of now, four types of meteograph print outs have been implemented in GME, namely *ymettype* = 'short', *ymettype* = 'long', *ymettype* = 'olong' and *ymettype* = 'elong'.

For *ymettype* = 'short' for each forecast step one line is written to a meteograph ASCII file for each grid point selected.

For *ymettype* = 'long' detailed information (including vertical profiles on all model layers) is printed for each forecast step and each grid point selected in a format similar to one used in the regional model LM.

ymettype = 'olong' or 'elong' writes detailed information in the old long format or with E-Format, i.e. with higher precision.

The ASCII meteograph files start with 'M_' followed by the name *ynamegp* of the grid point selected. A file called 'M_DESCRIPTION' which contains information about the variables printed is created, too.

Parameter	Type	Meaning of Parameter	Default
ngpmet	INT	Number of meteograph points selected	0
nstartmet	INT	Number of first meteograph step; If <i>nstartmet</i> > <i>nstop</i> , no meteographs will be printed. Alternatively	0
hstartmet	REAL	Same as <i>nstartmet</i> , but in hours	0.
nincmet	INT	Interval (in time steps) between two calls of the meteograph print out; if <i>nincmet</i> = 0, no meteographs will be printed. Alternatively:	0
hincmet	REAL	Interval (in hours) between two calls of the meteograph print out, if <i>hincdia</i> = 0., no meteographs will be printed.	1.
m1gpmet	INT	j1-index of grid point selected	0
m2gpmet	INT	j2-index of grid point selected	0
mdgpmet	INT	jd-index of grid point selected. Alternatively	0
zlongpmet	REAL	geographic longitude (in degree) of meteograph point (the GME grid point which is closest to this point is printed)	0.
zlatgpmet	REAL	geographic latitude (in degree) of meteograph point (the GME grid point which is closest to this point is printed)	0.
ynamegp	CH*20	Station name	' '
ymettype	CH*5	Type of meteograph 'short', 'long', 'elong', 'olong'	'short'

For each meteograph point, a new Namelist group &met_ctl has to be given.

Meteographs can be plotted with the perl-script **meteo_plot.pl** which employs **gnuplot**. On many computers at DWD the script is in directory `~hfrank/Perl`, or it can be obtained from Helmut.Frank@dwd.de. In addition `meteo_plot.pl` can plot diagnostic output from the files `OUTPUT_GME`, and `DIAGNOSTICS`.

8.3.7. &gribin - Control variables for the initial data (analysis/first guess)

Parameter	Type	Meaning of Parameter	Default
yanadir	CH*128	Directory path of initial data file	' '
nversana	INT	Version number of initial data (analysis)	1
yfgdir	CH*128	Directory path of first guess file (only for incremental DFI)	' '
yform_read	CH*4	Use libDWD, 'grb1', or GRIB API, 'apix', to read GRIB initial and first guess data	'grb1'
nsma_stat	INT	Status variable for soil moisture analysis (SMA); if set to 256 accept both 255 and 0	256

If gmtri is compiled without the libDWD library the default for yform_read is 'apix'.

For **idealized test cases**, the NAMELIST group **&gribin** is replaced by the group **&artif_ctl**

8.3.8. &artif_ctl - Control variables for the definition of idealized test cases

Parameter	Type	Meaning of Parameter	Default
ytst_case	CH*12	Test case identifier. For NCAR Idealized Test Case Suite in the form F-x-y where F: Test case family (1 to 6) x: Variant within one family (0 to 6) y: Passive tracer identifier (0 to 6) where y=0 corresponds to no passive tracer. Or, more general ID like F-x-yXXX (see below)	' '
zak (100)	REAL	Vertical coordinate parameter (pressure part); up to 100 values	0.
zbk (100)	REAL	Vertical coordinate parameter (sigma part); up to 100 values	0.
pertb_amp	REAL	Amplitude (m/s) of u-perturbation for test case 2 of the NCAR suite	1.
pertb_lat	REAL	Latitudinal centre position of perturbation	40.
pertb_lon	REAL	Longitudinal centre position of perturbation	20.
rotation_angle	REAL	Flow rotation angle for cases 1 to 3 (in degree)	0.
tau_u0	REAL	Period for u0 in case 3 (in days)	12.
tau_omega	REAL	Period for omega in case 3 (in days)	4.
itracer	INT	Number (type) of tracer for test cases 1 to 3. 0: no tracer; 1 to 4: for test cases 1 and 2; 5 and 6 for test case 3	0
lmono_o3	LOGICAL	Monotonic horizontal interpolation of passive tracer o3 in progexp	.false.

The [NCAR Suite](#) with a **test case identifier** in the form of **F-x-y** consists of the following six test case families (**F**):

- 1: Steady-state flow with a jet in each hemisphere (SS)
- 2: Baroclinic wave (BW)
- 3: Advection test, solid body rotation (AD)
- 4: 3D Rossby-Haurwitz wave (RH)

- 5: Mountain-induced Rossby wave (MR)
- 6: Gravity waves (*Pure gravity waves*: non-rotating, *Inertio-gravity waves*: rotating) (GW).

For test case families 1 to 3 the parameter x identifies the flow *rotation angle* α :

- 0: $\alpha = 0^\circ$; no rotation, flow parallel to the equator
- 1: $\alpha = 15^\circ$; flow confined to the tropics
- 2: $\alpha = 30^\circ$; subtropical flow
- 3: $\alpha = 45^\circ$; midlatitudinal flow
- 4: $\alpha = 60^\circ$; flow in the mid- to high latitudes
- 5: $\alpha = 75^\circ$; flow reaches high latitudes
- 6: $\alpha = 90^\circ$; flow straight over the poles

For test case families 4 and 5 the parameter x is set to 0.

For test case family 6 the parameter x distinguishes four variants:

- 0: No Earth rotation ($f = 0$); Brunt-Väisälä frequency $N = 0.01$ 1/s and $u_0 = 0$ m/s
- 1: No Earth rotation ($f = 0$); isotherm and $u_0 = 0$ m/s
- 2: No Earth rotation ($f = 0$); isotherm and $u_0 = 40$ m/s
- 3: With Earth rotation; isotherm and $u_0 = 0$ m/s

The parameter y denotes the initial passive tracer distribution:

- 0: no tracer for test case families 1, 4, 5 and 6
- 1 to 4: four different tracer distributions for test case families 1 and 2
- 5, 6: two different tracer distributions for test case family 3.

The tracer field is stored in the variable O3 (ozone) because GME treats ozone as a passive tracer.

Different parameters for the test cases can be specified using the parameters `pertb_amp` to `itracer` and test case identifiers SS, BW, AD, RH, MW, GW.

8.3.9. &gribout - Control variables and switches for the GME post-processing

This NAMELIST group may appear up to 20 times to define the writing of GRIB1 data. Data may be written out on the icosahedral-hexagonal model grid as well as on a regular geographical grid. Additionally, multi-level fields may be interpolated from model to pressure levels. Finally, some derived quantities like mean sea level pressure and relative humidity can be computed.

Parameter	Type	Meaning of Parameter	Default
ngrib	INT	Post-processing times in time steps; at most $max_nl_steps = 300$ may be defined here. Alternatively:	-1
hgrib	REAL	Same as <i>ngrib</i> , but in hours	-1.
ncomb	INT	Post-processing times in time steps as triplets: start, end, increment; at most $max_nl_comb = 10$ may be defined here. Alternatively:	-1
hcomb	REAL	Same as <i>ncomb</i> , but in hours	-1.
ysystem	CH*4	Type of data storage: 'daba': ORACLE data base (not yet impl.) 'file' : file in directory ydir (see below)	'file'

Parameter	Type	Meaning of Parameter	Default
		'ecfs': EC-file system (not yet implement.)	
ydir	CH*128	Directory of data base or file	' '
ydabapw	CH*10	Password of data base	' '
ykind	CH*1	Kind of result GRIB1 files: 'f': forecast data 'r': restart data (2 files: t, t+Δt)	'f'
yarea	CH*1	Area coding (for file name): 'f': full (global) domain	'f'
ytunit	CH*1	Time unit indicator (for file name): 't': time step in file name 'f': forecast mode (<i>hstop</i> ≤ 99d) 'c': climate mode (<i>hstop</i> > 99d)	'f'
yext	CH*1	Extension parameter of file name; 'p': Data interpolated to pressure levels	' '
ytype	CH*5	Type of data in data base, related to IPDS(4); e.g. 'r192f' or 'i192f'	'i f'
yform_write	CH*4	Write output data with libDWD in GRIB1, 'grb1', or using with GRIB API in GRIB1, 'api1', or GRIB2, 'api2'	'grb1'
yvarml	CH*10	Name of model level fields; at most <i>max_nl_varml</i> = 150 different names may be given (see Section 8 in this text).	' '
yvarpl	CH*10	Name of pressure level fields; at most <i>max_nl_varpl</i> = 50 different names may be given.	' '
plev	REAL	Pressure levels in Pa; at most <i>max_nl_plev</i> = 50 may be given. If plev(1)=0. Then 12 standard levels from 5000 to 100000 Pa are chosen.	0.
lcheck	LOGICAL	Logical switch, if .true. check the GRIB1 output data, i.e. print control quantities like maximum and minimum values of each out- put field.	.false.
lreg	LOGICAL	Logical switch, if .true. interpolate data from icosahedral-hexagonal model grid to regular latitude/longitude grid.	.false.
lpp_ini	LOGICAL	Logical switch, if .true. perform postprocess- ing for initialised step only	.false.
lntri10	LOGICAL	Write GRIBs with time flag 10, i.e. 2 bytes for the forecast time. However, quantities like ASHFL, AUMFL are averages from the start to the forecast time.	.false.
rinclon	REAL	Mesh size of regular latitude/longitude grid in west-east direction (in degree)	1.5
rinclat	REAL	Mesh size of regular latitude/longitude grid in south-north direction (in degree)	1.5
slon	REAL	Start longitude of (sub) domain (in degree; East: > 0)	9999.
slat	REAL	Start latitude of (sub) domain	9999.

Parameter	Type	Meaning of Parameter	Default
		(in degree; North: > 0)	
elon	REAL	End longitude of (sub) domain (in degree; East: > 0)	9999.
elat	REAL	End latitude of (sub) domain (in degree; North: > 0)	9999.
nrbit	INT	Number of bits per value for GRIB packing; usually 16 bits are enough. Restart files are written in full binary format to guarantee reproducibility. Values as big as 24 are pos- sible.	16
nvers	INT	Version number of model run	1

If gmtri is compiled without the libDWD library the default value for yform_write is 'api1'.

9. Using the post-processing functions

During post-processing GME writes out (normally to disk) GRIB1 code fields on model levels and interpolated to pressure levels, on the icosahedral-hexagonal model grid and interpolated to a regular geographical (latitude/longitude) grid (see section 10 for the naming convention of GME GRIB1 files).

The post-processing is controlled by the NAMELIST parameters of group / gribout /.

9.1. Writing data on the icosahedral-hexagonal model grid

Set *lreg* = .false.

Specify variables on model layers (and near-surface, surface and soil layers) by *yvarml*, e.g. *yvarml* = 'T', 'QV', 'T_2M'.

Specify variables on pressure levels (and the mean sea level pressure) by *yvarpl*, e.g. *yvarpl* = 'T', 'QV', 'PMSL'.

Specify the pressure levels (**ATTENTION: in Pa**) by *plev*, e.g. *plev* = 5000., 10000., 50000.

If no pressure levels have been specified in / gribout / GME uses as a default 12 standard pressure levels, namely 50, 100, 150, 200, 250, 300, 400, 500, 700, 850, 950, 1000 hPa. The vertical interpolation from model to pressure levels is based on tension splines except for relative humidity which is interpolated linearly.

The derived quantities relative humidity (*yvarpl* = 'RELHUM') and mean sea level pressure (*yvarpl* = 'PMSL') may be computed, too.

9.2. Writing data on a regular geographical (latitude/longitude) grid

Set *lreg* = .true. and specify the resolution of the geographical grid by *rinclon* and *rinclat* (in degree), e.g. *rinclon* = 0.75 *rinclat* = 0.75.

The defaults for *rinclon* and *rinclat* are 1.5 (°).

The northernmost latitude is specified by *rnlatt* (in degree), e.g. *rnlatt* = 90.

The geographical grid can be restricted to a part of the globe by specifying the variables *slon*, *slat*, *elon*, *elat*.

For the interpolation from the icosahedral-hexagonal model grid to the regular geographical grid there exist four options depending on the specific variable:

- Atmospheric variables are interpolated using a biquadratic interpolation formula based on the surrounding 12 grid points (Hermitian approach),
- Linear interpolation, based on the surrounding 3 grid points (barycentric coordinates), is used for some surface fields like orography,
- Match interpolation is used for those near-surface, surface and soil fields which strongly depend on the land/sea contrast. If the surface characteristic ("land" or "water") of the 3 GME grid points involved in the interpolation does not coincide, the linear interpolation is replaced by a "match", i.e. the corresponding grid point of the geographical grid receives the value of the closest GME grid point.
- Nearest point is used for those GME fields like the indices of convective cloud tops which cannot be interpolated. For those fields the points of the geographical grid receive the value of the closest GME grid point.

10. File name conventions

The file naming convention is closely related to the directory structure of the model runs since important information not contained in the file names has to be given in the names of the directories.

10.1. Naming convention for directories

The directory names should provide the following information

- * **experiment name** (or number), e.g. exp_13421
- * **type of model run**, e.g. assimilation, main run
- * **initial date of the forecast**, e.g. in the form `yyyymmddgg` where
yyyy: year, mm: month, dd: day, gg: time.

10.2. General form of file names of GME

10.2.1. Analysis files

The analysis file name has the following general form

yhead/'yyyymmddgg'/'yext

where

yhead (3 Character): File-Header, e.g.

gaf: GME analysis, full model domain

yyyymmddgg (10 Character): date in the form

yyyy: year

mm: month

dd: day

gg: hour

yext (1 Character): Extension, e.g.

p: data interpolated from model to pressure levels

Example:

gaf2001091612: GME analysis valid at 12 UTC on 16th of September 2001

10.2.2. Forecast files

The forecast file name has the following general form

yhead//ytunit/'xxxxxxxx'//yext

where

yhead (3 Character): File-Header, e.g.

gff: GME forecast, full model domain

ytunit (1 Character): Time unit of forecast range, e.g.

t: forecast range given in time steps

f: forecast mode: the forecast range is given in the form

ddhhmmss where

dd: day, hh: hour, mm: minute, ss: second

c: climate mode: the forecast range is given in the form

yyydddhh where

yyy: year, ddd: day, hh: hour

xxxxxxxx (8 Character): Forecast range in a form depending on ytunit.

yext (1 Character): Extension, e.g.

p: data interpolated from model to pressure levels

Examples:

gff06180000: GME forecast at day 6, 18 hours

gffc11223312p: GME forecast, climate mode, year 112, day 233, hour 12, interpolated from model to pressure levels

10.2.3. Valid file headers (yhead)

gaf: GME analysis (uninitialized), full model domain

gif: GME analysis or first guess (initialized), full model domain

gff: GME forecast, full model domain

grf: GME restart, full model domain

gfr: GME forecast, regular grid

gir: GME initialized analysis or forecast, regular grid

gar: GME analysis (uninitialized), regular grid

Notes:

Sub-domains can be denoted by a 3rd letter other than "f" or "r" which denotes the full domain or a regular grid.

The initialized analysis is identical to the 0-h forecast of the corresponding model, e.g. with the file name giff00000000; to facilitate a separate storage of initialized analysis files for later use, e.g. for diagnostic studies, the initialized analysis may be renamed to the analysis file form, i.e. gifyyyymmddhh where gif is the header of the initialized analysis of the full model domain.

11. GRIB Code Tables of GME variables

The **GR**idded **B**inary Code (GRIB, version1) is the standard input and output format of GME. If a field is defined in the standard WMO table (tab=2), GME uses this definition. Additionally, the national tables (tab=201, 202 and 203) are used. Thus a GRIB field is identified by an element number (**ee**) and a table number (**tab**).

The following Tables 11.1 to 11.5 list the name, element-nr (ee), table-nr (tab), level-type (lvtyp), level-top (lvt), level-bottom (lv) and physical unit of GRIB fields known to GME.

In the code the GRIB fields are listed in file **gme_gribtab.h** . The list in this file has a few more non-meteorological fields for diagnostic purposes.

11.1. Constant fields (d=invar, d=1111mm1111)

Name	Element	GME (GRIB 1)					Physical Unit
		Element-Nr. (EE)	Table-Nr.	Lev-Typ (LVTYP)	Levtop (LVT)	Levbot (LV)	
FIS	orography * g	6	WMO	1	-	-	m ² /s ²
Z0	roughness length; only land points! For water points Z0 will be computed based on Charnock's formula during the forecast run (see Table 11.4).	83	WMO	1	-	-	m
FR_LAND	land fraction of surface	81	WMO	1	-	-	1
SOILTYP	soil type of surface (key from 1 to 10); 1: ice, 2: rock, 3: sand, 4: sandy loam, 5: loam, 6: clay and loam, 7: clay, 8: peat, 9: sea water, 10: sea ice	57	202	1	-	-	1
RLAT	geographical latitude	114	202	1	-	-	Deg. N
RLON	geographical longitude	115	202	1	-	-	Deg. E
ROOTDP	root depth of vegetation	62	202	1	-	-	m
PLCOV_MX	plant cover of surface (vegetation period) =plcov_v	67	202	1	-	-	1
SSO_STDH	standard deviation of subgrid scale orography	46	202	1	-	-	m
SSO_GAMMA	anisotropy of subgrid scale orography	47	202	1	-	-	1
SSO_THETA	angle between principal axis of subgrid scale orography and global east	48	202	1	-	-	rad
SSO_SIGMA	mean slope of subgrid scale orography	49	202	1	-	-	1
FOR_E	ground fraction covered by evergreen forest	75	202	1	-	-	1
FOR_D	ground fraction covered by deciduous forest	76	202	1	-	-	1
LAI_MX	leaf area index (vegetation period)	69	202	1	-	-	1
T_2M	Climatological 2m-temperature used at lowest soil level	11	WMO	105	-	2	K
PRS_MIN	Minimum stomata resistance	212	201	1	-	-	s/m
EMIS_RAD	Surface emissivity	56	202	1	-	-	1
Datum: d=1111mm1111, mm=1,...,12. tflag=3							
NDVI_MRAT	Ratio of monthly mean NDVI to annual maximum	79	202	1	-	-	1
AER_SO412	Sulfat aerosol for 12 months	84	202	1	-	-	1
AER_DUST12	Dust aerosol for 12 months	86	202	1	-	-	1
AER_ORG12	Organic aerosol for 12 months	91	202	1	-	-	1
AER_BC12	Soot aerosol for 12 months	92	202	1	-	-	1
AER_SS12	Sea salt aerosol for 12 months	93	202	1	-	-	1

11.2. Multi-level fields on model levels

Name	Element	GME (GRIB 1)					Physical Unit
		Element-Nr. (EE)	Table-Nr.	Lev-Typ (LVTYP)	Levtop (LVT)	Levbot (LV)	
U	zonal wind	33	WMO	110	-	-	m/s
V	meridional wind	34	WMO	110	-	-	m/s
FI	Geopotential at half levels	6	WMO	109	-	-	m ² /s ²
T	temperature	11	WMO	110	-	-	K
QV	specific humidity	51	WMO	110	-	-	kg/kg
QC	specific cloud liquid water content	31	201	110	-	-	kg/kg
QI	specific cloud ice content	33	201	110	-	-	kg/kg
QR	specific rain water content (optional, depending on ntype_gsp)	35	201	110	-	-	kg/kg
QS	specific snow content (optional, depending on ntype_gsp)	36	201	110	-	-	kg/kg
O3	ozone mixing ratio (optional), or tracer for artificial test cases.	180	202	110	-	-	kg/kg
OMEGA	vertical velocity $\omega = dp/dt$	39	WMO	110	-	-	Pa/s
CLC	Cloud cover	29	201	110	-	-	%
GEN_TEN1	Generalized tendency depending on ygen_ten in namelist &gme_ctl	234	201	110	-	-	?/s
GEN_TEN2	Generalized tendency depending on ygen_ten in namelist &gme_ctl	235	201	110	-	-	?/s

11.3. Fields of the multi layer soil model

Name	Element	GME (GRIB 1)					Physical Unit
		Element-Nr. (EE)	Table-Nr.	Lev-Typ (LVTP)	Levtop (LVT)	Levbot (LV)	
T_SO	soil temperature	197	201	111	-	Tiefe	K
W_SO	water content of soil layer (liquid and frozen)	198	201	111	-	in	mmH ₂ O
W_SO_ICE	ice content of soil layer	199	201	111	-	cm	mmH ₂ O

The soil temperatures are defined for the nine levels 0, 0.5, 2, 6, 18, 54, 162, 486 and 1458 cm in soil. The temperature at the interface soil – atmosphere is identical to the temperature at the depth of 0.5 cm. The temperature at level 1458 cm is set to the climate average of the 2m-temperature.

WARNING: As the depth could only be coded in whole centimetres in GRIB1 Code, the depth of 0.5 cm will be coded as 1 cm.

Water and ice content are computed for the six soil layers 0 – 1, 1 – 3, 3 – 9, 9 – 27, 27 – 81, 81 – 243; the layers 243 – 729 and 729 – 2187 are kept constant in time.

11.4. Single-level fields

Name	Element	GME (GRIB 1)					Physical Unit
		Element-Nr. (EE)	Table-Nr.	Lev-Typ (LVTYP)	Levtop (LVT)	Levbot (LV)	
PS	surface pressure on model orography	1	WMO	1	-	-	Pa
T_SNOW	temperature at the top of snow or surface temperature	203	201	1	-	-	K
T_S	temperature at the bottom of snow or surface temperature (if no snow)	85	WMO	111	-	0	K
T_G	surface temperature (weighted from T_S and T_SNOW); if no snow: T_G = T_S = T_SNOW. Over water, T_G is kept constant during the model run.	11	WMO	1	-	-	K
T_M	temperature at a depth of ~ 8 – 10 cm of the old 2-layer soil model	85	WMO	111	-	9	K
QV_S	specific humidity at the surface; over water, this corresponds to 100% relative humidity.	51	WMO	1	-	-	kg/kg
W_SNOW	water content of snow	65	WMO	1	-	-	mmH ₂ O
RHO_SNOW	snow density	133	291	1	-	-	kg/m ³
H_SNOW	snow depth	66	WMO	1	-	-	m
W_I	water content of interception storage	200	201	1	-	-	mmH ₂ O
W_G1	water content of upper soil layer (0 – 10 cm) of the old 2-layer soil model	86	WMO	112	0	10	mmH ₂ O
W_G2	water content of lower soil layer (10 – 100 cm) of the old soil model	86	WMO	112	10	100	mmH ₂ O
TCM	turbulent transfer coefficient for momentum at the surface	170	201	1	-	-	1
TCH	turbulent transfer coefficient for heat and moisture at the surface	171	201	1	-	-	1
ASOB_S	solar radiation balance at the surface; mean over forecast period	111	WMO	1	-	-	W/m ²
ATHB_S	thermal radiation balance at the surface; mean over forecast period	112	WMO	1	-	-	W/m ²
APAB_S	photosynthetic active radiation balance at the surface; mean over forecast period	5	201	1	-	-	W/m ²
ALB_RAD	(solar) shortwave albedo at the surface	84	WMO	1	-	-	%
ASOB_T	solar radiation balance at the top of the atmosphere ; mean over forecast period	113	WMO	8	-	-	W/m ²
ATHB_T	thermal radiation balance at the top of the atmosphere ; mean over forecast period	114	WMO	8	-	-	W/m ²

Name	Element	GME (GRIB 1)					Physical Unit
		Element-Nr. (EE)	Table-Nr.	Lev-Typ (LVTYP)	Levtop (LVT)	Levbot (LV)	
RAIN_GSP	rain (grid-scale precipitation), accumulated since start of the forecast	102	201	1	-	-	kg/m ²
SNOW_GSP	snow (grid-scale precipitation), accumulated since start of the forecast	79	WMO	1	-	-	kg/m ²
RAIN_CON	rain (convective precipitation), accumulated since start of the forecast	113	201	1	-	-	kg/m ²
SNOW_CON	snow (convective precipitation), accumulated since start of the forecast	78	WMO	1	-	-	kg/m ²
PREC_GSP	Grid scale precipitation (RAIN_GSP+SNOW_GSP)	62	WMO	1	-	-	kg/m ²
PREC_CON	Convective precipitation (RAIN_CON+SNOW_CON)	63	WMO	1	-	-	kg/m ²
TOT_PREC	Total precipitation (PREC_GSP+PREC_CON)	61	WMO	1	-	-	kg/m ²
RUNOFF_S	surface water run-off; accumulated since start of the forecast.	90	WMO	112	0	10	kg/m ²
RUNOFF_G	ground water run-off; accumulated since start of the forecast.	90	WMO	112	10	100	kg/m ²
U_10M	zonal wind 10m above ground	33	WMO	105	-	10	m/s
V_10M	meridional wind 10m above ground	34	WMO	105	-	10	m/s
T_2M	temperature 2m above ground	11	WMO	105	-	2	K
TD_2M	dew point temperature 2m above ground	17	WMO	105	-	2	K
TMIN_2M	minimum of temperature 2m above ground	16	WMO	105	-	2	K
TMAX_2M	maximum of temperature 2m above ground	15	WMO	105	-	2	K
VMAX_10M	maximum wind speed 10m above ground (including gusts)	187	201	105	-	10	m/s
Z0	roughness length (land and water points)	83	WMO	1	-	-	m

Name	Element	GME (GRIB 1)					
		Element-Nr. (EE)	Table-Nr.	Lev-Typ (LVTYP)	Levtop (LVT)	Levbot (LV)	Physical Unit
CLCT	total cloud cover	71	WMO	1	-	-	%
CLCH	high cloud cover (0 – 400 hPa)	75	WMO	1	-	-	%
CLCM	medium cloud cover (400 – 800 hPa)	74	WMO	1	-	-	%
CLCL	low cloud cover (800 hPa – surface)	73	WMO	1	-	-	%
BAS_CON	base index of main convective cloud (index of vertical level)	72	201	1	-	-	1
TOP_CON	top index of main convective cloud (index of vertical level)	73	201	1	-	-	1
HBAS_CON	height of cloud base above msl	68	201	2	-	-	m
HTOP_CON	height of cloud top above msl	69	201	3	-	-	m
HTOP_DC	height of top of dry convection above msl	82	201	1	-	-	m
AUMFL_S	average u-momentum flux at the surface; averaged since start of forecast	124	WMO	1	-	-	kg/(m·s ²)
AVMFL_S	average v-momentum flux at the surface; averaged since start of forecast;	125	WMO	1	-	-	kg/(m·s ²)
ASHFL_S	average sensible heat flux at the surface; averaged since start of forecast	122	WMO	1	-	-	W/m ²
ALHFL_S	average latent heat flux at the surface; averaged since start of forecast	121	WMO	1	-	-	W/m ²
CLDEPTH	modified cloud depth for media (e. g. TV) representation of clouds	203	203	1	-	-	-
CLCT_MOD	modified cloud cover for media (e. g. TV) representation of clouds	204	203	1	-	-	-
HZEROCL	height of 0°C level above mean sea level	84	201	4	-	-	m
TQV	total water vapour content (integral over column)	54	WMO	1	-	-	kg/m ²
TQC	total cloud water content (integral over column)	76	WMO	1	-	-	kg/m ²
TQI	total cloud ice content (integral over column)	58	WMO	1	-	-	kg/m ²
TQR	total rain water content (optional; integral over column)	37	201	1	-	-	kg/m ²
TQS	total snow content (optional; integral over column)	38	201	1	-	-	kg/m ²

Name	Element	GME (GRIB 1)					Physical Unit
		Element-Nr. (EE)	Table-Nr.	Lev-Typ (LVTYP)	Levtop (LVT)	Levbot (LV)	
TO3	total ozone content (integral over column), or total artificial tracer content.	10	WMO	1	-	-	Dobson
FRESHSNW	weighting function indicating 'freshness' of snow in upper few centimeters of snow cover (for albedo)	129	201	1	-	-	1
FR_ICE	ice fraction for ocean or lake surfaces	91	WMO	1	-	-	1
H_ICE	sea ice thickness	92	WMO	1	-	-	m
T_ICE	ice surface temperature or water surface temperature	215	201	1	-	-	K
CAPE_ML	Conv. Available pot. Energy of mean surface layer parcel	145	201	1	-	-	J/kg
CIN_ML	Conv. Inhibition of mean surface layer parcel	146	201	1	-	-	J/kg
VIO3	ozone content, vertically integrated (climatological)	65	202	1	-	-	Pa(O ₃)
HMO3	height of ozone maximum (climatological)	64	202	1	-	-	Pa
PCLOV	plant cover of surface	87	WMO	1	-	-	%
LAI	Leaf area index	61	202	1	-	-	1
NDVIRATIO	Ratio of actual NDVI to annual maximum (Time flag tflag=0)	79	202	1	-	-	1
AER_SO4	Sulfat aerosol	84	202	1	-	-	1
AER_DUST	Dust aerosol	86	202	1	-	-	1
AER_ORG	Organic aerosol	91	202	1	-	-	1
AER_BC	Soot aerosol	92	202	1	-	-	1
AER_SS	Sea salt aerosol	93	202	1	-	-	1
ASWDIR_S	Direct downward short wave radiation at the surface	22	201	1	-	-	W/m ²
ASWDIFD_S	Diffuse downward short wave radiation at the surface	23	201	1	-	-	W/m ²
ASWDIFU_S	Diffuse upward short wave radiation at the surface	24	201	1	-	-	W/m ²

11.5. Fields interpolated to pressure levels or to MSL

Name	Element	GME (GRIB 1)					Physical Unit
		Element-Nr. (EE)	Table-Nr.	Lev-Typ (LVTYP)	Levtop (LVT)	Levbot (LV)	
U	zonal wind	33	WMO	100	-	-	m/s
V	meridional wind	34	WMO	100	-	-	m/s
FI	geopotential	6	WMO	100	-	-	m ² /s ²
T	temperature	11	WMO	100	-	-	K
RELHUM	relative humidity	52	WMO	100	-	-	%
QV	specific humidity	51	WMO	100	-	-	kg/kg
QC	specific cloud liquid water content	31	201	100	-	-	kg/kg
QI	specific cloud ice content	33	201	100	-	-	kg/kg
QR	specific rain water content (optional)	35	201	100	-	-	kg/kg
QS	specific snow content (optional)	36	201	100	-	-	kg/kg
O3	ozone mixing ratio (optional), or artificial tracer.	180	202	100	-	-	kg/kg
OMEGA	vertical velocity $\omega = dp/dt$	39	WMO	100	-	-	Pa/s
PMSL	surface pressure, reduced to mean sea level	2	WMO	102	-	-	Pa
CRI	contrail index	5	205	100	-	-	GJ/(200 m)

11.6. Initial fields to start GME

The following fields are required to start GME:

- Invariant fields of
FIS, FR_LAND, T_2M (climatological mean), ROOTDP,
SSO_STDH, SSO_GAMMA, SSO_THETA, SSO_SIGMA,
SOILTYP, PLCOV_MX, LAI_MX, FOR_D, FOR_E, PRS_MIN, EMIS_RAD,
all 12 months of NDVI_MRAT, AER_SO412, AER_DUST12, AER_ORG12,
AER_BC12, AER_SS12
- 3D-fields on model levels:
U, V, T, QV, QC, QI, O3 (optional), QR & QS (depending on lana_qrqs)
- Fields of the soil model (8+1 layers for T_SO; 8 layers for W_SO and W_SO_ICE):
T_SO, W_SO, W_SO_ICE
- Single level fields:
Z0, PS, QV_S, W_I,
T_SNOW, W_SNOW, RHO_SNOW, FRESHSNW,
FR_ICE, H_ICE, T_ICE

This makes $87 + 9 \cdot 60 + 25 + 11 = 663$ GRIB fields for the operational 60 level model GME30L60.

For the incremental digital filter initialization (IDFI, `ldfi_incr=.true.`) GME needs first guess values of the fields PS, U, V, T, QV, QC, QI, QR, and QS. For the operational 60 level model this first guess file contains $8 \cdot 60 + 1 = 481$ GRIB fields.

The actual vegetation characteristics is calculated from the given monthly climatological vegetation characteristics in the following way: From NDVI_MRAT calculate the climatological ratio for the actual date and scale PLCOV_MX and LAI_MX to compute PLCOV and LAI corresponding to this date.

T_2M (climatological mean) is used as fixed lower boundary condition for the soil model at a depth of 1458 cm.

12. Computer resources needed by GME

12.1. Horizontal resolution and number of grid points per layer

GME may use different horizontal resolutions, determined by the NAMELIST parameter ni in / gme_ctl /. ni must be of the form: $ni = 3^{ni3} * 2^{ni2}$ where $ni3 = 0$ or 1 and $ni2$ integer. This is due to the grid generation procedure which allows an initial bi- or trisection of the main triangle sides which have a length of 7054 km. After the initial step only bisections are performed until there are ni intervals on a main triangle side. Thus the mesh size Δ on the diamond edges is roughly given by $\Delta \sim 7054 \text{ km}/ni$; the *average mesh size* on the globe is slightly larger (by about 10%). Over the globe, the mesh size varies by some 25%, only. The number of grid points per layer (ngp) is given by

$$ngp = (ni + 1)^2 * 10$$

including the common diamond edges. There are $ngp_u = ni^2 * 10 + 2$ unique grid points in the icosahedral-hexagonal grid.

Tab. 12.1 gives ngp for different horizontal resolutions ni and mesh sizes Δ .

Table 12.1 Number of grid points per layer (ngp) of GME at different horizontal resolutions ni and average mesh sizes Δ (km).

ni	32	48	64	96	128	192
Δ (km)	241	161	120	80	60	40
ngp	10890	24010	42250	94090	166410	372490

ni	256	384	512	768	1024	1536
Δ (km)	30	20	15	10	7.5	5
ngp	660490	1482250	2631690	5913610	105062500	23623690

12.2. Vertical resolution

The vertical resolution of GME is determined by the NAMELIST parameter $i3e$ in group / gme_ctl /.

12.3. Total memory requirements

Most memory space required by GME is allocated at the beginning of the forecast in SUBROUTINE *allocate_fields* depending on the horizontal resolution parameter ni and number of layers $i3e$. Here, all prognostic, diagnostic and constant fields are allocated as 2-, 3-, 4, or 5-dimensional arrays. For prognostic variables, three time levels ($t-\Delta t$, t , $t+\Delta t$) are allocated.

All in all

$$\begin{aligned} & (ni + 1)^2 (10*(221+ 24*i3e +8*i3e_{soil}) + 7) + \\ & (ni + 2)^2 * 2 \quad \quad \quad + \\ & (ni + 3)^2 * (48 + 10*2*i3e) + \\ & (ni + 5)^2 *10*(12 + 32*i3e) \end{aligned}$$

words are allocated. Normally 8 Bytes per word are used (64 Bit precision).

Additionally, the digital filtering initialization requires in the SUBROUTINE *df_ini* the allocation of

$$(ni + 1)^2 * 10 * (1 + 8 * i3e)$$

words. At the end of *df_ini*, this storage is de-allocated.

Finally, local storage in the order of additional 40% is required for temporary work space, and in the post-processing routines.

Thus the total memory requirement of GME (in Byte) with a horizontal resolution *ni* and number of layers *i3e* is given by

$$8*1.4* ((ni + 1)^2 (10*(221+ 24*i3e+8*i3e_{soil}) + 7) + (ni + 2)^2 * 2 + (ni + 3)^2 * (48 + 10* 2*i3e) + (ni + 5)^2 * 10*(12 + 32*i3e) (ni + 1)^2 * 10 *(1 + 8 * i3e))$$

Tab. 12.2 shows the HWM (High Water Mark in GByte) of memory for GME at different horizontal resolutions *ni* and the fixed number of layers *i3e* = 60.

Table 12.2 HWM (High Water Mark in GByte) of memory for GME at different horizontal resolutions *ni* and the fixed number of layers *i3e* = 60.

ni	32	48	64	96	128	192	256	384
HWM (GByte)	0.58	1.24	2.13	4.66	8.17	18.10	31.94	71.34

If GME is using many processors (e. g. nproc1 = 7 and nproc2 = 16) the communication buffers and the halo regions of the horizontal domain at each processor will increase these memory requirements.

12.4. Total CPU requirement of GME

Computing a full radiation step every 1 hour, a GME time step including explicit dynamics, semi-implicit correction and all physical parameterizations costs about

$$4100 \text{ Flop/ (grid point, layer, time step).}$$

The semi-implicit time step Δt depends on the horizontal resolution *ni* according to Tab. 12.3.

Table 12.3 Semi-implicit time step Δt (s) depending on the horizontal resolution *ni*.

ni	32	48	64	96	128	192	256	384
Δt (s)	800	533.3	400	266.7	200	133.3	100	66.7

Thus the total cost (*CP(24-h)*) of a 24-h forecast is given by

$$CP(24-h) = 4100 * (ni + 1)^2 * 10 * i3e * 24 * 3600 / \Delta t \text{ (Flop).}$$

Tab. 12.4 shows the total cost of a 24-h forecast at different horizontal resolution ni ; the number of layers $i3e$ is set to 40.

Table 12.4 Total cost ($CP(24-h)$) of a 24-h forecast depending on the horizontal resolution ni ; the number of layers $i3e$ is set to 60.

ni	32	48	64	96	128	192	256	384
CP(24-h) (TFlop)	0.26	0.87	2.0	6.8	16.1	54.0	127.7	429.8

For operational applications at DWD, a 24-h forecast should be completed in less than 20 minutes (including I/O of GRIB fields). Thus the sustained speed of the computer on which GME is running operationally must exceed $CP(24-h) / 1200s$ (Flops = Flop/s).

Table 12.5 Sustained speed (GFlops) required to run a 24-h forecast operationally (in less than 30 minutes) depending on the horizontal resolution ni ; the number of layers $i3e$ is set to 60.

ni	32	48	64	96	128	192	256	384
Speed (GFlops)	0.22	0.73	1.7	5.7	13.4	45	106	358

13. NAMELIST Input of IFS2GME

13.1. Introduction

GME can either use analyses of the GME or the IFS (Integrated Forecasting System of the European Centre for Medium Range Weather Forecasts, Reading, UK) as initial data. To retrieve IFS data from the MARS archive the user needs an account (with a smart card) at the ECMWF. For more information please contact Dr. H. Frank (Helmut.Frank@dwd.de).

The program *IFS2GME* will interpolate the IFS data to the horizontal and vertical grid of the GME. The resolution and truncation of the IFS data have to be taken according to the resolution of GME. The resulting GRIB file will satisfy the GME name convention for first guess or analysis. It is possible to take a forecast file of *hstep* hours and relabel it to a first guess file of a new forecast step and the corresponding initialisation date or to an analysis file with a new initialisation date of (date + hstep).

ECMWF's sea ice model employs a constant ice thickness of 1.5 m. Hence, variable ice thickness *H_ICE* cannot be interpolated. It is possible to provide *FR_ICE*, *H_ICE*, *T_ICE* in a separate sea ice file. Otherwise, ECMWF's thickness of 1.5 m must be used, or GME must run without the sea ice model, i.e. set *lsea_ice=.false.*

Since version 2.27 *IFS2GME* will interpolate initial values for rain water content, *QR*, and snow content, *QS*, if these fields are present in the IFS data which is read by *IFS2GME*. Otherwise, they are not written to the output GRIB file and GME must be run with *lana_qrqs=.false.*

Also, since version 2.27 *IFS2GME* uses GRIB API routines to read IFS data in order to be able to read data in GRIB2 as well as GRIB1 format. It is important to use GRIB definition table files, set by environment variable *GRIB_DEFINITION_PATH*, which contain the DWD variable names, and which are compatible with the GRIB API version when the executable was linked. Since version 2.30 *IFS2GME* can write GRIB1 and GRIB2 with GRIB API routines. As in main program *gmtri* this is controlled by the namelist variable *yform_write*.

Since version 2.28 uses either the IFS fields *LNSP*, logarithm of surface pressure, and geopotential at the surface on hybrid model layer 1, *FI*, or surface pressure *SP*, and surface geopotential as surface variable, *FIS*, to interpolate surface pressure from IFS to GME. The previous usage of **LNSP and FIS** is much worse and **no longer accepted**. The combination of *LNSP* and *FI* is recommended as it yields somewhat smoother atmospheric fields.

Also, if IFS soil types, *SLT*, are included in the input fields, then the soil moisture index is used to interpolate soil moisture. On average this yields somewhat drier soil which is in better agreement of soil moisture from the operational model at DWD. *SLT* is available since IFS cycle 32r3 which is operational at ECMWF since 6 November 2007. I.e. *SLT* is not available for ECMWF's reanalyses, ERA-40, and ERA-Interim.

Analogous to GME, the control parameters of *IFS2GME* are contained in an ASCII file called **INPUT_IFS2GME**. They are split into the four different NAMELIST groups which have to appear in the following order in the file **INPUT_IFS2GME**:

/ifs_grid/ - the variables describe the horizontal and vertical resolution of the spectral IFS, they are contained in **COMMON** block
/gme_pr_paramgm/

- /gme_grid/** - the variables describe the horizontal and vertical resolution of the GME grid, they are contained in COMMON block /gme_param/
- /data/** - control variables, file names and switches for the input and output data of the program, they are contained in COMMON block /gme_pr_comorg/
- /dia/** - control variables, file names and switches for the diagnostic output of IFS2GME, they are contained in COMMON block /gme_pr_comdia/

ECMWF data, i.e. analyses of the Integrated Forecasting System (IFS), can be taken from the operational archive plus the re-analysis archive (ERA-40, 1957 – 2001, ERA-Interim, 1979 to present). With these data it is possible to run a GME forecast for any case during this period.

13.2. Example of INPUT_IFS2GME file

```
&ifs_grid
  nlat=800, nlon=1600, nlev=83, nlev_s=9,
/
&gme_grid
  ni=256, i3e=60, i3e_soil=7, pcon_lev=300.e2,
  ak_gme_nl = 0, 1000, 2000, 3000,
    4000, 5000, 6000, 6999.99425458,
    7998.35588615, 8990.00678856, 9969.17920361, 10930.5724125,
    11875.6582035, 12805.4198816, 13721.9792261, 14619.9524815,
    15493.1921307, 16331.0571692, 17122.7770595, 17855.2373095,
    18516.5958989, 19094.8478105, 19579.6603819, 19962.3672791,
    20236.2884654, 20396.9784586, 20441.7594114, 20370.3647682,
    20183.5734023, 19884.8793324, 19478.4528759, 18969.9501705,
    18366.5784651, 17676.2366002, 16907.6584586, 16070.3695782,
    15172.8442296, 14227.4389276, 13244.6269865, 12235.4564244,
    11210.996926, 10182.2126304, 9159.90267912, 8154.59415002,
    7176.3717652, 6234.64651599, 5338.50577819, 4495.86454004,
    3714.34995639, 2999.95086825, 2357.91874918, 1792.46992646,
    1306.45218906, 901.04989839, 575.587452427, 328.662376494,
    156.592722419, 52.6980514866, 6.57562752681, 0.00316071949724,
    0,
  bk_gme_nl = 0, 0, 0, 0,
    0, 0, 0, 5.74542115104e-08, 1.64411384672e-05,
    9.99321144457e-05, 0.000308207963893, 0.00076231713817,
    0.00157750085244, 0.00292563156702, 0.0049433742111, 0.0078196073704,
    0.0117289866697, 0.0168702231358, 0.0234234247551, 0.0315732218046,
    0.041473583688, 0.0532631547311, 0.0670478817747, 0.0829020555395,
    0.100866092049, 0.120945031162, 0.143114186873, 0.167313691856,
    0.193463137195, 0.221445856328, 0.251130294618, 0.282362895248,
    0.314968427413, 0.348759562628, 0.383536421326, 0.419087987834,
    0.455260876576, 0.491753107092, 0.528349984684, 0.564821877966,
    0.600940624871, 0.636481785871, 0.671226219611, 0.70496213467,
    0.737487773594, 0.76861470775, 0.798165317282, 0.825982259933,
    0.851920606619, 0.875862327332, 0.897708262785, 0.917382083311,
    0.934834603883, 0.95004771412, 0.963037324748, 0.973843017799,
    0.98254455373, 0.989270042695, 0.994204163725, 0.997630118393,
    1.,
/
&data
  ydate_ini='2011092012', hstep=0, hinc_fg=0,
  yfn_gme_topo='invar.i256a',
  ygme_topodir='/cla/tmp/ms/BATCH/4/cla0301.9388794.0/dat/gme/h/12/',
  yfn_ifs_g='ecf2011092012',
  yifs_gdir='/cla/tmp/ms/de/dfr/invar/gme/const/',
  ygmedir='/cla/tmp/ms/BATCH/4/cla0301.9388794.0/dat/gme/h/12/',
  yform_write='apil',
  lsnow_ifs=.true.,
  lsnow_g=.true.,
  lsurf=.true., lsoil_lin=.false., lprog_o3=.true.,
  lfor_ana=.true., lfor_fg=.true., lwrite_inv=.false.,
/
&dia
  lprps=.false., lprt=.false., lpru=.false., lprv=.false.,
  lprqv=.false., lprsf=.false., lprgp=.true.,
  lprqc=.false., lprqi=.false., lpro3=.false.,
/
```

13.3. Explanation of the different control variables and switches

13.3.1. /ifs_grid/ - Control variables for the IFS grid

Parameter	Type	Meaning of Parameter	Default
nlat	INT	Number of gridpoints of the IFS data in the S-N direction in the Gaussian grid.	512
nlon	INT	Number of gridpoints of the IFS data in W-E direction in the Gaussian grid.	1024
nlev	INT	Number of layers in the atmosphere; the number of model levels (layer interfaces) is nlev + 1.	60
nlev_s	INT	Starting IFS level of input data, i.e. nlev_s=5, nlev=87 read IFS levels 5 to 91=nlev_s-1+nlev.	1

13.3.2. /gme_grid/ - Control variables for the GME grid

Parameter	Type	Meaning of Parameter	Default
ni	INT	Resolution of GME, i.e. the number of intervals on a main triangle side, to which the IFS data shall be interpolated	192
i3e	INT	Number of GME model layers; the number of model levels (layer interfaces) is i3e + 1.	40
i3e_soil	INT	Number of soil model layers	7
pcon_lev	REAL	Pressure at the control level (used to adjust the interpolated surface pressure) in Pa	300.e2
ak_gme_nl	REAL(100)	Vertical coordinate ak in the namelist input	0 (<i>must be given</i>)
bk_gme_nl	REAL(100)	Vertical coordinate bk in the namelist input	0 (<i>must be given</i>)

13.3.3. /data/ - Control variables and switches for the input and output data

Parameter	Type	Meaning of Parameter	Default
yfn_gme_topo	CH*14	File name of GME topographical data. If no topographical data are given the data will be interpolated from the IFS data.	' '
ygme_topodir	CH*128	Directory path of GME topographical data	' '
yfn_ifs_g	CH*24	File name of the IFS data on the Gaussian grid (there is no convention how it should be named).	' '
yifs_gdir	CH*128	Directory path of IFS data on Gaussian grid.	' '
ygmedir	CH*128	Directory path where the interpolated GME data will be written, the file name is according to the convention in GME.	' '
yform_write	CH*4	Use libDWD, 'grb1', to write GRIB1 data, or GRIB API to write GRIB1, 'api1', or GRIB2, 'api2', data	'grb1'
nvers	INT	Version number of output data	1
ydate_ini	CH*10	Initial date and time of the forecast (see gme_ctl)	' '
hstep	REAL	Forecast step in hours to be interpolated. For analysis: hstep = 0.	0.
hinc_fg	REAL	Forecast length of first guess to which the forecast time shall be relabelled.	3.
lfor	LOGICAL	Logical switch for IFS analysis data (lfor=.false.) or forecast data at time <i>hstep</i> (lfor=.true.). The second option will include interpolating some more forecast fields of IFS which is not implemented yet.	.false.
lfor_fg	LOGICAL	As lfor, but only initialisation fields will be written out. Additionally, the analysis date and forecast time will be relabeled for 'first guess' so that the new forecast time is <i>hinc_fg</i> .	.false.
lfor_ana	LOGICAL	As lfor_fg, but the date and forecast time will be relabeled for 'analysis', valid at the date of the IFS forecast time <i>hstep</i> .	.false.
lwrite_inv	LOGICAL	Logical switch for GME constant fields to be written out (.true.), or not (.false.)	.true.
lsnow_ifs	LOGICAL	.true. when the IFS snow temperature shall be set; otherwise the GME snow temperature will be interpolated from the radiation and ground surface temperatures.	.false.
lsnow_g	LOGICAL	.true. when the GME snow temperature will additionally to the presetting be interpolated by $\text{snow-cover} * t_g + (1 - \text{snow-cover}) * t_{\text{snow}}$ (for fully covered regions the result will be t_{skin} of IFS)	.true.
lsoil_lin	LOGICAL	.true. if soil temperatures shall be calculated by linear interpolation instead of bulk interp.	.false.

Parameter	Type	Meaning of Parameter	Default
lsurf	LOGICAL	.true. when the surface data shall be interpolated and written to 'yfn_gme'; otherwise they have to be taken separately from the GME data base	.true.
lprog_o3	LOGICAL	Ozone switch (see gme_ctl)	.false.
laqua	LOGICAL	Interpolate for an aqua planet	.false.
lint_uv	LOGICAL	Interpolate and write winds U, V if .true.	.true.
lsea_ice	LOGICAL	Interpolate sea ice fraction, temperature, thickness	.false.
ysea_ice	CH*256	File name (full path) of climatological (GME) sea ice data	' '
nvers	INT	Version number for output data	1

13.3.4. /dia/ Control variables and switches for diagnostics

The diagnostics are written to the file **OUTPUT_IFS2GME**. Multi-level fields are printed for two levels `ipr_lev1` and `ipr_lev2`, for already interpolated GME fields the level will be at most `i3e`.

Parameter	Type	Meaning of Parameter	Default
ipr_lev1	INT	First level/layer of multi-level fields to be printed	2
ipr_lev2	INT	Second level/layer of multi-level fields to be printed	nlev
i1pr	INT (10)	First index of gridpoints to be printed	10*3
i2pr	INT (10)	Second index of gridpoints to be printed	10*6
idpr	INT (10)	Third index (diamond) of gridpoints to be printed	1,2,...,10
lprps	LOGICAL	Logical switch for printing the surface pressure during the interpolation	.false.
lprt	LOGICAL	Logical switch for printing the temperature during the interpolation	.false.
lpru	LOGICAL	Logical switch for printing the u-component of wind during the interpolation	.false.
lprv	LOGICAL	Logical switch for printing the v-component of wind during the interpolation	.false.
lprqv	LOGICAL	Logical switch for printing the specific humidity during the interpolation	.false.
lprqc	LOGICAL	Logical switch for printing the cloud water content during the interpolation	.false.
lprqi	LOGICAL	Logical switch for printing the cloud ice during the interpolation	.false.
lpro3	LOGICAL	Logical switch for printing the ozone during the interpolation	.false.
lprsf	LOGICAL	Logical switch for printing some surface fields during the interpolation	.false.
lprgp	LOGICAL	Logical switch for printing the diagnostic points during the interpolation. 10 gridpoints with indices (i1pr, i2pr, idpr) can be selected to print out the values.	.false.

Computer resources needed by IFS2GME

IFS2GME is not parallelized. Therefore all fields have to be within the memory of one processor. In most routines this is not a problem because the data are stored in direct access files and therefore it is possible to compute the different fields separately. Only for the vertical interpolation all vertical layers of both IFS and GME are needed for one variable.

The total memory requirement (in Byte) is

$$i\text{bytes} * (ni+1)^2 * 10 * \text{MAX}(2*nlev+15, nlev+i3e+9)$$

(*ibytes* is the machine precision in Byte).

For *ibytes*=8, *i3e*=31 or *i3e*=40 and *nlev*=60 this means about 0.18GB for *ni*=128, 0.40GB for *ni*=192, and 0.71GB for *ni*=256.

For the direct access files

$i\text{bytes} * (nlon * nlat * (8 * nlev+24))$	(2.15 GB) are necessary for the original IFS fields,
$i\text{bytes} * (ni+1)^2 * 10 * (9 * nlev+22)$	(1.67 GB) for the horizontally interpolated IFS fields,
$i\text{bytes} * (ni+1)^2 * 10 * (7 * i3e+2 * i3e_soil+42)$	(1.00GB) for the GME fields

have to be allocated in temporary files.

If *lint_uv*, *lsurf*, or *lprog_o3* are *.false*. less data is interpolated and the direct access file are smaller.

The values in brackets are for the following IFS and GME resolutions:
nlev=60, *nlat*=512, *nlon*=1024 and *i3e*=40, *ni*=192.

14. Usage of GME2GME

14.1. Introduction and overview

The program GME2GME transforms GME datasets from one horizontal and vertical resolution to another. GME2GME is part of the GME library and corresponds to the latest GME version. Note: With version 2.30 *GME2GME* still uses the libDWD GRIB library for input and output.

GME2GME reads a start data file *gafyyyyymmddgg* from the input directory *ydir_i*, where *yyyyymmddgg* is the initial date of the forecast. The file contains analysis (or forecast data) of the horizontal resolution *ni_i* and the vertical resolution *ie_i*. This file also contains the invariant data of the input grid. The invariant data of the output grid is read from the file *invar.ixxxa* in the directory *ytopodir*, where *xxx* specifies the output resolution *ni_o*. If *ytopodir* is not set, the external parameters for the output grid will be interpolated from the input grid. If *ytopodir* is set, but the file *invar.ixxxa* does not exist, the program will abort.

ATTENTION:

The filename of the input data must be *gafyyyyymmddgg*.

The filename of the topographical data must be *invar.ixxxa* (*xxx* = *ni_o*)

The results of the program are written to the output file *gafyyyyymmddgg*, which is in the directory *ydir_o*. The name of the output file can be changed by setting *yhead* (first 3 characters of the file) and / or *yext* (1 character extension to the file).

In case *ydir_i*=*ydir_o*, identical *yhead* (=gaf) and missing extension *yext*, the result file will get the header "new" (i.e. *newyyyyymmddgg*).

The content of the output file can be controlled by several namelist switches.

Analogous to GME and IFS2GME the control parameters are in the input file INPUT_GME2GME, containing the following namelists (for details see 12.2):

- /gme2gme_ctl/ : GENERAL control variables and switches
- /gribin/ : Directory, filename of INPUT
- /gribout/ : Directory, filename of OUTPUT
- /dia/ : Control variables and switches for DIAGNOSTICS

Horizontal interpolation of surface fields is performed as in GME taking into account the land-sea-characteristic of the output grid. For the interpolation of surface temperatures also the dependency on height is considered. Vertical interpolation is done as in IFS2GME.

GME2GME uses the actual GRIB-table *gme_gribtab.h*, defining the variables.

Switches/parameters in the input-namelists can be used to control, which fields should be transformed:

- Normal case: Transformation of a complete initial data file *gafyyyyymmddgg* OR
- List of fields (*yvar_nl*): This is only possible for single surface fields WITHOUT vertical interpolation and output of invariant data.

It is possible, to transform forecast data. As the program always reads a file named *gafyyyyymmddgg*, forecast data and invariant data of input grid have to be copied to this file. For example, if you want to transform data for *vv*=48 from a forecast starting at 13/07/2006, 00UTC, GME2GME needs an input data data set *gaf2006071300* (*hstep*=48) and results are written to the file *gaf2006071500*.

GME2GME is a parallelized program (domain decomposition for input and output grids will be done); therefore the program can easily deal with finer resolutions, which need more memory, and requires less time for computation than IFS2GME.

The following graphics gives an overview of the main program *gme2gmeorg* :

Main program of GME2GME: *gme2gmeorg*

PREPARATIONS

- Initialization of „fpe_trap“ and „MPI“
- Reading in of NAMELISTs : *gme2gme_readnlist*
- Parallelization: domain decomposition (*gme2gme_domain_decomposition*), communication setup (*gme2gme_setup_xd*)
- Allocation of all fields: (*gme2gme_allocate_fields*)
- Opening of files (*gme2gme_get_data*), reading in of data (*gme2gme_read_data*)
- Grid generation for input- and output- grid (*gme2gme_gengrids*)

TRANSFORMATION

- (1) Horizontal interpolation (*gme2gme_setup_horint*, (*gme2gme_extpar*), *gme2gme_horint*)
- (2) Vertikal interpolation (*gme2gme_verint*)
 - pressure correction 1 (*gme2gme_pcor1*)
 - temperature , moisture → correction of moisture (*gme2gme_moist_corr*)
 - pressure correction 2 (*gme2gme_pcor2*)
 - wind

DIAGNOSTICS

- after horizontal interpolation (*gme2gme_diaprt1*)
- after vertikal interpolation (*gme2gme_diaprt2*)

FINAL WORK

- Output in GRIB1 (*gme2gme_output_org*)
- Finishing of MPI

14.2. NAMELISTs and Defaults

The following tables describe the NAMELIST variables and their defaults. The defaults correspond to the latest GME version; this has to be taken into account if dealing with older data sets.

In Chapter 15.3 examples of different input files INPUT_GME2GME are presented to illustrate the usage for different purposes.

To get started, the initial time *ydate_ini* of the GME data input file, the directory *ydir_i*, where this file can be found and the directory path *ytopodir* for the topographical data of output grid (if present) have to be given.

14.2.1. /gme2gme_ctl/ - General control variables and switches

Parameter	Type	Meaning of Parameter	Default
ni_i	INT	Resolution of GME input grid	192
ni_o	INT	Resolution of GME output_grid	96
<i>ni is the number of intervals on a main triangle side, ni must be of the form $ni = 3^{ni3} * 2^{ni2}$, where $ni3 = 0$ or 1 and $ni2 \geq 0$.</i>			
i3e_i	INT	Number of model layers of the input grid	40
i3e_o	INT	Number of model layers of the output grid The number of model levels (layer interfaces) is $i3e + 1$.	i3e_i
ak_o_nl	REAL(100)	Vertical coordinate parameter ak of output grid	0.
bk_o_nl	REAL(100)	Vertical coordinate parameter bk of output grid	0.
<i>If not given: defaults are taken for i3e_o=31, 40, or 60. If i3e_o=i3e_i: ak_o=ak_i, bk_o=bk_i.</i>			
i3e_soil_i	INT	Number of active soil model layers of input grid (if lsoil_in = .true.)	7
i3e_soil_o	INT	Number of active soil model layers of output grid (if lsoil_out = .true.)	7
<i>Layer i3e_soil+1 is considered as climate layer.</i>			
pcon_lev	REAL	Pressure at the control level (<i>used to adjust interpolated surface pressure; the geopotential at 300hPa is forced to be the same in input and output data</i>)	300.E2 (300hPa)
ydate_ini	CHAR*10	Initial date of the forecast in the form yyyymmddgg, where yyyy: year, e.g. 1999 mm: month, e.g. 06 dd: day, e.g. 25 gg: time, e.g. 18 (UTC)	has to be given
hstep	REAL	Forecast time in hours	0.
nproc1	INT	Number of processors used in j1-direction on MPP machines (e.g. IBM p575). For message passing, MPI (Message Passing Interface) is used.	1
nproc2	INT	Same as <i>nproc1</i> , but for j2-direction; with <i>nproc1</i> and <i>nproc2</i> the usual 2-D domain decomposition is performed on a diamond. The $(ni + 1)^2$ grid points of a diamond are divided among the <i>nproc1</i> * <i>nproc2</i> processing elements (PEs). Each PE holds data of all 10 diamonds	1
yvar_nl (max_var_num)	CHAR*10	List of variables (max_var_num = 160) to be interpolated; alternative to complete "gaf"-File, Either the complete data (default) or the single level fields specified in yvar_nl (no vertical interpolation) and no output of inv. data (linv_out=F)	'blank'

Parameter	Type	Meaning of Parameter	Default
SWITCHES			
* for information: to control input and output			
* for variables: if .true., variable should be transformed			
ldebug	LOGICAL	Debug switch	.false.
lsoil_in	LOGICAL	Input is 7-layer soil model	.true.
lsoil_out	LOGICAL	Output is 7-layer soil model	.true.
<i>All combinations of lsoil_in and lsoil_out are possible except lsoil_in=T and lsoil_out=F.</i>			
lhoriz	LOGICAL	Horizontal interpolation required <i>In case of ni_o=ni_i and different external parameters this switch forces interpolation</i>	.false. <i>ni_i/=ni_o => .true.</i>
linv_out	LOGICAL	Output of invariant data, e.g. topography	.true.
lprog_qi	LOGICAL	Cloud ice (field qi) switch	.true.
lprog_o3	LOGICAL	Ozon /field o3) switch	.true.
lprog_qrqs	LOGICAL	Prognostic precipitation (fields qr and qs) switch	.false.
lforest	LOGICAL	Forest fields (fields for_e and for_d) switch	.true.
lprog_rs	LOGICAL	Density of snow switch	.true.
lndvi_i	LOGICAL	NDVI switch – input data	.true.
lndvi_o	LOGICAL	NDVI switch – output data	.true.
laerosol_i	LOGICAL	Aerosol variables in input file	.true.
laerosol_o	LOGICAL	Aerosol variables in output file	.true.
lssso	LOGICAL	SSO variable switch	.true.
lsea_ice	LOGICAL	Sea ice switch	.true.
qvmin	REAL	Minimum value of water vapour (security)	1.E-12
qcmin	REAL	Minimum value of cloud liquid (security)	1.E-12
qimin	REAL	Minimum value of cloud ice (security)	1.E-12
qrmin	REAL	Minimum value of rain water content (security)	1.E-12
qsmin	REAL	Minimum value of snow content (security)	1.E-12
o3min	REAL	Minimum value of ozone content (security)	1.E-20
l_date_grib_act	LOGICAL	Actual creation date in GRIB file; if .false., identical files are comparable with ‘cmp’	.true.
experiment_ID	CHAR*16	Character for experiment information	‘blank ‘

14.2.2. /gribin/ - Declarations for INPUT data

Parameter	Type	Meaning of Parameter	Default
ydir_i	CHAR*128	Directory path of input data file	has to be given
nversana	INTEGER	Version number of initial data	1
ytopodir	CHAR*128	Directory path of topographical data for output (!) resolution. <i>In case of empty directory, the external parameters will be interpolated from input topographical data. The filename always has the form invar.ixxxa with xxx = ni_o. i.e. invar.i128a!!</i>	‘blank’ has to be given if external par. exist for ni_o

14.2.3. /gribout/ - Declarations for OUTPUT data

Parameter	Type	Meaning of Parameter	Default
ydir_o	CHAR*128	Directory path of output file (if not given ydir_o = ydir_i; if ydir_o=ydir_i and same header of file, yhead='new')	'blank'
yhead	CHAR*3	Header of file	'blank'
ykind	CHAR*1	'a'nalysis file	'a'
yarea	CHAR*1	Area coding, 'f'ull domain	'f'
yext	CHAR*1	Extension parameter	'blank'
ytype	CHAR*6	Type of data (DWD extension, i.e. i192a) (if ni_o > 999, ytype='ixxxxa')	ixxxa xxx:ni_o
lcheck	LOGICAL	.true. for check of GRIB data	.false.
nrbit	INTEGER	Number of bits for GRIB packing	16
nvers	INTEGER	Version number of model	1

14.2.4. /dia / - Diagnostics

10 diagnostic gridpoints can be defined, for which the diagnostic output will be done. For each gridpoint, the program opens a file in the working directory, named DIA01, DIA02, DIA03, ..., DIA10.

Parameter	Type	Meaning of Parameter	Default
lprgp	LOGICAL	Switch for printing the diagnostics gridpoints; 10 gridpoints can be selected (ipr1, ipr2, iprd)	.false.
i1pr	INTEGER(10)	First index of gridpoints to be printed	10 * 3
i2pr	INTEGER(10)	Second index of gridpoints to be printed	10 * 6
idpr	INTEGER(10)	Third index (diamond) of gridpoints to be printed	1, 2, 3, ..., 10
ipr_lev1	INTEGER	First level/layer of multi-level fields to be printed	2
ipr_lev2	INTEGER	Second level/layer of multi-level fields to be printed	i3e_o
lprps	LOGICAL	Switch for printing the surface pressure	.false.
lprt	LOGICAL	Switch for printing the temperature	.false.
lpru	LOGICAL	Switch for printing the u-component of wind	.false.

Parameter	Type	Meaning of Parameter	Default
lprv	LOGICAL	Switch for printing the v-component of wind	.false.
lprqv	LOGICAL	Switch for printing the specific humidity content	.false.
lprqc	LOGICAL	Switch for printing the cloud water content	.false.
lprqi	LOGICAL	Switch for printing the cloud ice content	.false.
lprqr	LOGICAL	Switch for printing the rain water content	.false.
lprqs	LOGICAL	Switch for printing the snow content	.false.
lpro3	LOGICAL	Switch for printing the ozone content	.false.

14.3. Examples for INPUT_GME2GME

(1) Old data – old soil scheme

An ‘old’ data file from 2001092318 with resolution $ni_i=128/i3e_i=31$ and old soil scheme should be transformed to current GME version ($ni_o=192/i3e_o=40$ and 7 layer soil scheme).
 NAMELIST input file INPUT_GME2GME:

```
&gme2gme_ctl
  i3e_i=31,
  i3e_o=40,           ! Vertical coordinate parameters ak_o and bk_o are default.
  ni_i=128,
  ni_o=192,
  nproc1=2, nproc2=4,
  ydate_ini='2001092318',
  lsoil_in=.false.,  ! Input data have old soil scheme
  lndvi_i=.false.,  ! Input data do not contain NDVI data
/
&gribin
  ydir_i='/uwork0/for1lie/gme2gme/start/data/', ! Directory for start data gaf2001092318
  ytopodir='/uwork0/for1lie/gme2gme/start/data/', ! Directory for topographical data invar.i192a
/
&gribout
  ydir_o='/uwork0/for1lie/gme2gme/new/', ! Directory for result file gaf2001092318
  yhead="",
  yext="",
  lcheck = .true.
/
&dia           ! No diagnostics
```

(2) No change in resolution, but new external parameters

Adaption of a data set to new external parameters with the same resolution:

```
INPUT_GME2GME
&gme2gme_ctl
  i3e_i=40,
  ni_i=192,
  ni_o=192,
  nproc1=2, nproc2=4,
  ydate_ini='2007011300',
  lhoriz = .true.,
  lndvi_i=.false.,
  linv_out=.false.,
/
&gribin
  ydir_i='/uwork0/for1lie/gme2gme/start/data/',
  ytopodir='/uwork0/for1lie/gme2gme/start/data/',
/
&gribout
  ydir_o='/uwork0/for1lie/gme2gme/new/',
  yhead='NEW',
  lcheck = .true.,
/
&dia
/
```

! Input and output resolution are the same!

! Force horizontal interpolation.

! NO output of invariant data.

! Header NEW for result file: NEW2007011300.

(3) Transformation of an actual data set to higher resolution

a) Interpolation to higher horizontal resolution, no topographical data set given

```
INPUT_GME2GME
&gme2gme_ctl
  i3e_i=40,
  i3e_o=40,
  ni_i=192,
  ni_o=256,
  nproc1=4, nproc2=4,
  ydate_ini='2008011318',
/
&gribin
  ydir_i='/uwork0/for1lie/gme2gme/start/data/',
  ytopodir="",
/
&gribout
  ydir_o='/uwork0/for1lie/gme2gme/new/',
  yhead="",
  yext="",
  lcheck = .true.,
/
&dia
/
```

! More processors are required than before.

! The invariant data of output resolution will be interpolated from input data.

b) Interpolation to higher vertical resolution with diagnostics

There are $i3e_o=60$ layers with 61 vertical coordinate parameters ak_o_{nl} and bk_o_{nl} given. The grid point diagnostics are switched on via $lprps$, so files DIA01, DIA02, ..., DIA10, which can be found in the working directory, contain the diagnostics for the 10 grid points (3,6,1:10). With $lprps$ the printing of the surface pressure is switched on.

```
&gme2gme_ctl
  i3e_i=40,
  i3e_o=60,
  ak_o_nl = 0.0000, 100.0000, 200.0000, 320.4706, 479.9565,
            695.1369, 980.8870, 1323.5972, 1710.6907, 2130.5912,
            2572.6909, 3027.3179, 3485.7041, 3939.9527, 4383.0064,
            4808.6144, 5211.3008, 5586.3320, 5929.6843, 6238.0120,
            6508.6146, 6739.4050, 6928.8770, 7076.0731, 7180.5521,
            7242.3567, 7261.9817, 7240.3413, 7178.7370, 7078.8250,
            6942.5845, 6772.2848, 6570.4537, 6339.8444, 6083.4038,
            5804.2403, 5505.5910, 5190.7897, 4863.2348, 4526.3567,
            4183.5857, 3838.3198, 3493.8922, 3153.5389, 2820.3669,
            2497.3217, 2187.1548, 1892.3915, 1615.2990, 1357.8537,
            1121.7088, 908.1627, 718.1260, 552.0895, 410.0920,
            291.6879, 195.9150, 121.2621, 65.6368, 26.3333,
            0.0000,
  bk_o_nl = 0.0000000, 0.0000000, 0.0000000, 0.0000000, 0.0000000,
            0.0000000, 0.0000000, 0.0002674, 0.0010425, 0.0025393,
            0.0049466, 0.0084287, 0.0131267, 0.0191590, 0.0266225,
            0.0355936, 0.0461288, 0.0582659, 0.0720249, 0.0874090,
            0.1044053, 0.1229858, 0.1431085, 0.1647184, 0.1877478,
            0.2121181, 0.2377403, 0.2645157, 0.2923372, 0.3210903,
            0.3506536, 0.3809001, 0.4116980, 0.4429117, 0.4744027,
            0.5060303, 0.5376529, 0.5691289, 0.6003173, 0.6310788,
            0.6612771, 0.6907792, 0.7194567, 0.7471867, 0.7738527,
            0.7993456, 0.8235644, 0.8464174, 0.8678231, 0.8877110,
            0.9060224, 0.9227119, 0.9377476, 0.9511126, 0.9628056,
            0.9728422, 0.9812552, 0.9880963, 0.9934363, 0.9973667,
            1.0000000,
  ni_i=192,
  ni_o=192,
  nproc1=2, nproc2=4
  ydate_ini='2008011318',
  linv_out=.false.,
/
&gribin
  ydir_i='/uwork0/for1lie/gme2gme/start/data/',
  ytopodir='/uwork0/for1lie/gme2gme/start/data/',
/
&gribout
  ydir_o='/uwork0/for1lie/gme2gme/new/',
  yhead="",
  yext='X',
  lcheck = .true.
/
&dia
  lprgp=.true.,
  lprps=.true.,
/
```

(4) Interpolation of list of fields

These examples give the input files to transform single fields and not a complete initial data file. If *yvar_nl* is set, the single level fields given will be transformed without vertical interpolation and output of invariant data.

a) Climatological 2m-temperature

```
INPUT_GME2GME
```

```
&gme2gme_ctl
```

```
  i3e_i=40,
```

```
  ni_i=192,
```

```
  ni_o=128,
```

```
  nproc1=2, nproc2=4
```

```
  ydate_ini='2007011300',
```

```
  yvar_nl='T_2M',
```

```
  lndvi_i=.false.,
```

```
/
```

```
&gribin
```

```
  ydir_i='/uwork0/for1lie/gme2gme/start/data/',
```

```
  ytopodir='/uwork0/for1lie/gme2gme/start/data/',
```

```
/
```

```
&gribout
```

```
  ydir_o='/uwork0/for1lie/gme2gme/new/',
```

```
  yhead="",
```

```
  yext='A',
```

```
  lcheck = .true.
```

```
/
```

```
&dia
```

```
/
```

List of variables to be transformed

Result file will be gaf2007011300A

b) Sea ice variables

It is enough to set *yvar_nl='T_ICE'* in example (4)a), then the program will interpolate FR_ICE, H_ICE, T_ICE and T_SO as well to get a consistent data set.

(5) Interpolation of forecast data

It is possible to interpolate forecast data, when the input file gafyyymmddgg contains the forecast and invariant data of the input grid. The following INPUT_GME2GME transforms forecast data from 2008011318 + 48h (set *ydate_ini* plus *hstep*), result file is gaf2008011518.

```
&gme2gme_ctl
```

```
  i3e_i=40, ni_i=192,
```

```
  i3e_o=40, ni_o=256,
```

```
  nproc1=4, nproc2=4,
```

```
  ydate_ini='2008011318',
```

```
  hstep=48,
```

```
          forecast hour
```

```
/
```

```
&gribin
```

```
  ydir_i='/uwork0/for1lie/gme2gme/start/data/',
```

```
  ytopodir="",
```

```
&gribout
```

```
  ydir_o='/uwork0/for1lie/gme2gme/new/',
```

```
  yhead="", yext="",
```

```
  lcheck = .true.
```

```
/
```

```
&dia
```

```
/
```

Appendix: Calling Tree for GME

14.4. Calling tree for main program gmeorg

gmeorg	Main program of GME
initialize_fpe_trap	
mpi_init	
mpi_errhandler_set	
mpi_comm_size	
mpi_comm_rank	
init_timing	Initialize timing
readnlst	Reads the namelists
readnlpp	Read postprocessing namelists gribout
ini_pp_addfld	Initialize var_pp for output of additional fields
add_nstep_pp	Set time steps for calculation of additional fields
mpe_io_init	Initialize the module for asynchronous IO
mpe_io_reconfig	
domain_decomposition	Domain Decomposition
setup_xd	Setup for xd_p
allocate_fields	Allocate all fields used in GME
setup_vartab_1	Generate the table for GRIB-code variables contained in /gme_comio/
setup_vartab	
setconst1	Setting physical, mathematical, and some parameterization constants
If GME is using artificial initial data (lartif_data = .true.) do not call the following two subroutines (get_sd, read_sd)	
get_sd	Opens the GRIB file(s) with the start data
read_sd or read_sd_api	Read the start data file(s) of GME
get_ndvi	Calculate actual NDVI
gengrid	Generate grid and calculate operators
factorni	Factorize ni into 3**ni3 * 2**ni2
glo_coor	Calculate global coordinates
dxdhmin	Calculate the minimum mesh width and minimum height of the grid
loc_coor	Calculate local coordinates
tri_area	Calculate the areas of the triangles
hex_area	Calculate the areas of the hexagons and the weights of the gridpoints
gen_grd	Calculate gradient and Laplacian operator
gen_vert	Calculate the parameters related to the vertical grid;
read_tuning_constants	Read tuning constants (usually not done)
setconst2	Set additional (grid dependent) constants
If GME is using artificial initial data (lartif_data = .true.) compute the artificial initial state in subroutine artif_data	
artif_data	Compute the artificial initial state
setup_reg_grids	Set up for output of regular grids
setup_verint	Set up for output on pressure levels
setup_meteograph	Set up the the meteograph files
timing	
df_ini	Perform a digital filter initialization (DFI), if required
dolph	Calculate Dolph-Chebyshev filter window
cheby	Calculate Chebyshev polynomials
progorg	Adiabatic backward integration
condens	Effects of condensation/evaporation
dolph	

cheby	
progorg	Diabatic forward integration
condens	
read_fg_incr or read_fg_incr_api	Read and add first guess increments for IDFI
progorg	Forward time stepping of model
df_ini	If required do DFI at last forecast step
progorg	Forward step only to organize output
timing_summary	
mpe_io_shutdown	Stop asynchronous IO
mpe_io_node	
mpi_finalize	

14.5. Calling tree for time stepping routine progorg

progorg	Organizes the time stepping of GME
prog_s_01	
condens	Calculates effects of condensation/evapoaration on T, qv, qc
geopot	Calculates the geopotential at half and full levels for all layers
timing	
ext_prg	Extends the variables by 2 rows and columns
timing	
read_sst or read_sst_api	Read sea surface temperature every nday_sst days for seasonal runs
get_ndvi	Calculate actual NDVI
get_aerosol	Calculate actual aerosol
prog_s_02	
sltraj	Computes the semi-Lagrange 2-d trajectory
barycen	Calculates the barycentric coordinates
interp2lv	Interpolates the vector field (pu,pv) linearly
barycen	
physics	Parameterization of diabatic processes (except prognostic grid scale precipitation scheme)
timing	
xd_p	Extends qrs_gsp (for diagnostic grid scale precipitation scheme)
timing	
prog_s_03	
progexp	Calculates the explicit forecast of the GME for ps, T, qv, qc, qi, O3, u, v
grad2s	Calculate pressure gradient
div2v	Calculate the horizontal mass divergence
hdiff_s	Horizontal diffusion of surface pressure
vor2v	Compute relative vorticity
hdiff_v	Horizontal diffusion of u, v
grad2s	Gradient of T
hdiff_s	Horizontal diffusion of T, qv
interp2qs	Interpolate qv, qc, qi, o3 to departure point of particle trajectory
timing	
ext_prg	
timing	
prog_s_04	
sikor1	Computes right-hand-sides of Helmholtz equations of the semi-implicit time stepping
lap2s	Compute Laplacian of 2. temp. derivative of generalized potential
div2v	Compute divergence of 2. temp. derivative of horizontal wind
timing	

prog_s_05	
sicor2	Solves the 2-d Helmholtz equations for mode kj3
sor	Successive Over-Relaxation (SOR) scheme
timing	
prog_s_06	
sicor3	Back-transformation of the solution of the 2-d Helmholtz equationn; adds the SI corrections to the values of the prognostic fields
grad2s	
condens	
timing	
mass_correction	Mass correction of surface pressure if required
timing	
ext_prg	
timing	
micro_physics	Prognostic grid scale precipitation scheme if ntype_gsp=2 or 3
prog_s_07	
target_dif	Targeted smoothing of water vapour field
condens	
asselin	Asselin filtering of prognostic variables
condens	
nearsfc	Computes the near surface fields
calqvs	Calculation of surface humidity over water
timing	
ext_prg	
timing	
dia_phys	Computes global mean quantities for diagnostic purposes and prints in file DIAGNOSTICS
glo_sum	
timing	
diagnos	Computes global mean quantities each timestep, prints values in standard output file
glo_sum	
glo_max	
timing	
meteograph	Prints meteographs
caladdfld	Computes additional fields:
caltopdc	height of top of dry convection
calclmod	modified cloud depth, modified cloud cover
calhzero	height of 0 C-level
calverintegr	total content of qv, qc, qi, qr, qs, O3
caloldsoil	compute variables of the old soil scheme
cal_conv_ind	compute CAPE, CIN
timing	
pporg	Organizes the post-processing
timing	
flush_dia	Flush diagnostic output files
make_fn	Write ready-files

14.6. Calling tree of subroutine physics

physics	Parameterisation of diabatic processes
date_time	Compute actual date and time
pargsp_qi	Grid-scale precipitation if ntype_gsp=1
parclc	Calculation of partial cloud cover, related layer properties for radiative transfer scheme
parrad	Longwave and shortwave radiation
calc_smu0	Calculation of solar zenith angle
solar_parameters	Calculate solar parameters
aerosol_opt	Parameters for optical depth of different aerosols and vertical distribution
ozone	Parameters of a T5 spectral distribution of ozone depending on the time of year
legtri_vec	Legende function for triangular truncation
fesft	Organise the radiative transfer calculations
opt_th	Optical properties of the non-gaseous constituents for one spectral interval in the thermal spectrum
inv_th	Solve the linear system of equations for thermal fluxes
coe_th	Optical effects of atmospheric layers on thermal radiation based on basic optical properties of non-gaseous constituents and gaseous absorption coefficients
opt_so	Optical properties of the non-gaseous constituents for one spectral interval in the solar spectrum
inv_so	Solve the linear system of equations for solar fluxes
coe_so	Optical effects of atmospheric layers on solar radiation based on basic optical properties of non-gaseous constituents and gaseous absorption coefficients
date_time	
partura	Calculate atmospheric turbulent exchange coeff.
parturs	Calculates turbulent transfer coefficients in surface layer
moist_c	Calculate fields which are needed in the moist convection scheme
grad2s	Calculate gradient of scalar
div2v	Calculate the 2-d divergence of horizontal wind
interp2qs	Quadratic interpolation of qv
grad2s	
parcon	Organise the mass flux cumulus convection scheme
cu_ini	Initialization of cumulus convection arrays
cu_base	Calculate cloud base parameters
cu_asc	Perform cloud ascent calculations
cu_dlfs	Calculate level of free sinking for downdrafts
cu_ddraf	Perform cumulus downdraft calculations
cu_asc	Perform cloud ascent calculations
cu_flux	Calculates final values of convective fluxes
cu_dtdq	Calculate surface precipitation and tendencies of T and qv due to convection
cu_dudv	Calculate momentum tendencies due to convection
parsoil_a	First part of the soil process parameterisation
parsoil_b	Second part of soil process parameterisation
parssso	Subgrid-scale orographic effects
sso_setup	Set up parameters for SSO scheme
gw_stress	Compute gravity stress amplitude
gw_profil	Compute vertical profile of gravity wave stress
parsea_ice	Sea ice model

14.7. Calling tree for post-processing subroutine pporg

pporg	Organize post-processing
pp_verint	Vertical interpolation on p-levels
pp_makegribs	Pack fields in GRIB code and write them out
pp_open_file	Open output file
make_fn	Create output file name
mpe_io_open	Open the output file (asynchronous IO)
copen	Open the output file
pp_output	Do the output
pp_output_init	initializes output for namelist *namelist*
pp_timecode	Set unit of time and time range indicator
pp_makegds_reg	Grid definition section for regular grid
pp_makegds_tri	Grid definition section for triangular grid or using GRIB API
pp_makegrid_reg	
pp_makegrid_tri	
pp_interp2qv	\ \ Interpolate to regular grid / / if necessary
grad2v	
pp_interp2lv	
pp_interp2qs	
grad2s	
pp_interp2ls	/
pp_output_slice	Gather slices from the different processors
pr_check_fld_p	Check field if required
pp_output_flush	Final treatment of output
pp_makepds	Make GRIB product definition section
eps_extend_grib1	Write EPS extensions in PDS if necessary
grbex1	Pack data in GRIB format
cuegex	Write packed data to file
mpe_io_write	Write packed data to file (asynchronous IO) or with GRIB API
pp_makepdt	
grib_set, grib_get_message_size, grib_get, grib_copy	
mpe_io_close	Close the output file (asynchronous IO)
cclose	Close the output file or
grib_close	

15. References

- Baumgardner, J. R., 1983: A three-dimensional finite element model for mantle convection. Thesis, University of California, 271 p.
- Baumgardner, J. R. and P.O. Frederickson, 1985: Icosahedral discretization of the two-sphere. *SIAM J. Numer. Anal.*, Vol. 22, No. 6, 1107-1115.
- Baumgardner, J. R., 1985, "Three-dimensional treatment of convective flow in the earth's mantle", *J. Stat. Phys.*, 39, 501-511.
- Baumgardner, J. R., 1995, A semi-implicit semi-Lagrange method for the shallow water equations on a triangular mesh, Fourth CHAMMP Workshop for the Numerical Solution of PDE's in the Spherical Geometry, Chicago.
- Burridge, D.M., 1975: A split semi-implicit reformulation of the Bushby-Timpson 10-level model. *Quart. J. Roy. Meteor. Soc.*, 101, No. 430, 777-792.
- Doms, G. and U. Schättler, 2003: The nonhydrostatic limited-area model LM (Lokal-Modell) of DWD. Part I: Scientific Documentation. Deutscher Wetterdienst (DWD), Offenbach, March 2003.
- Dutton, J.A., 1976: The ceaseless wind, McGraw-Hill, Inc., pp 579.
- Heikes, R. and D. A. Randall, 1995a: Numerical integration of the shallow-water equations on a twisted icosahedral grid. Part I: Basic design and results of tests. *Mon. Wea. Rev.*, 123, 1862-1880.
- Heikes, R. and D. A. Randall, 1995b: Numerical integration of the shallow-water equations on a twisted icosahedral grid. Part II: A detailed description of the grid and an analysis of numerical accuracy. *Mon. Wea. Rev.*, 123, 1881-1887.
- Heise, E. and R. Schrodin, 2002: Aspects of snow and soil modelling in the operational short range weather prediction models of the German Weather Service. *Journal of Computational Technologies*, Vol. 7, Special Issue: Proceedings of the International Conference on Modelling, Databases and Information Systems for Atmospheric Science (MODAS), Irkutsk, Russia, June 25-29, 2001, 121-140.
- Jacobsen, I. and E. Heise, 1982: A new economic method for the computation of the surface temperature in numerical models. *Beitr. Phys. Atm.*, 55, No. 2, 128-141.
- Lott, F. and M. Miller, 1997: A new sub-grid scale orographic drag parameterization: its formulation and testing. *Quart. J. Roy. Meteor. Soc.*, 123, 101-128.
- Louis, J.-F., 1979: A parametric model of vertical eddy fluxes in the atmosphere. *Boundary-Layer Meteor.*, 17, 187-202.
- Lynch, P., 1997: The Dolph-Chebyshev window: A simple optimal filter. *Mon. Wea. Rev.*, 125, 655-660.
- Majewski, D. 1998: The new global icosahedral-hexagonal grid point model GME of the Deutscher Wetterdienst, ECMWF, Seminar Proceedings, Recent developments in numerical methods for atmospheric modelling, 173-201.
- Majewski, D., D. Liermann, P. Prohl, B. Ritter, M. Buchhold, T. Hanisch, G. Paul, W. Wergen and J. Baumgardner, 2000: The global icosahedral-hexagonal grid point model GME - Operational version and high resolution tests -. ECMWF, Workshop Proceedings, Numerical methods for high resolution global models.
- Majewski, D., D. Liermann, P. Prohl, B. Ritter, M. Buchhold, T. Hanisch, G. Paul, W. Wergen and J. Baumgardner, 2002: The operational global icosahedral-hexagonal grid point model GME: Description and high resolution tests. *Mon. Wea. Rev.*, 130, 319-338.
- Masuda, Y. and H. Ohnishi, 1986: An integration scheme of the primitive equations model with an icosahedral-hexagonal grid system and its application to the shallow water

- equations. Proc. WMO/IUGG Symp. on Short- and Medium-Range Numerical Weather Prediction. Tokyo, Japan, Japan Meteorological Society, 317-326.
- Mellor, G.L. and T. Yamada, 1974: A hierarchy of turbulence closure models for planetary boundary layers. *J. Atmos. Sci.*, 31, 1791-1806.
- Müller, E., 1981: Turbulent flux parameterization in a regional-scale model. ECMWF Workshop on planetary boundary layer parameterization, 193-220.
- Mironov, D. and B. Ritter, 2003: A first version of the ice model for the global NWP system GME of the German Weather Service. WGNE Blue Book.
- Mironov, D., and B. Ritter, 2004: A New Sea Ice Model for GME. Technical Note, Deutscher Wetterdienst, Offenbach am Main, Germany, 12 pp.
http://nwpi.krc.karelia.ru/flake/papers/MR_SeaIce_GME_DWDintern.ps
- Ritter, B. and J.-F. Geleyn, 1992: A comprehensive radiation scheme for numerical weather prediction models with potential applications in climate simulations. *Mon. Wea. Rev.*, 120, 303-325.
- Robert, A., 1981: A stable numerical integration scheme for the primitive meteorological equations. *Atmos. Ocean*, 17, 35-46.
- Sadourny, R., A. Arakawa and Y. Mintz, 1968: Integration of the non-divergent barotropic vorticity equation with an icosahedral-hexagonal grid for the sphere. *Mon. Wea. Rev.*, 96, 351-356.
- Seifert, A., 2003: A Revised Cloud Microphysical Parameterization for COSMO-LME, COSMO Newsletter, 7, 25-28.
- Simmons, A. J. and D. M. Burridge, 1981: An energy and angular-momentum conserving vertical finite-difference scheme and hybrid vertical coordinate. *Mon. Wea. Rev.*, 109, 758-766.
- Staniforth, A. and J. Côté, 1991: Semi-Lagrangian integration schemes for atmospheric models – A review. *Mon. Wea. Rev.*, 121, 2206-2223.
- Stuhne, G. R. and W. R. Peltier, 1996: Vortex erosion and amalgamation in a new model of large scale flow on the sphere. *J. Comput. Phys.* 128, 58.
- Stuhne, G. R. and W. R. Peltier, 1999: New icosahedral grid-point discretizations of the shallow water equations on the sphere. *J. Comput. Phys.* 148, 23-58.
- Tegen, I., P. Hollrig, M. Chin, I. Fung, D. Jacob, and J. Penner, 1997: Contribution of different aerosol species to the global aerosol extinction optical thickness: Estimates from model results. *J. Geophys. Res.*, 102, 23895-23915, doi:10.1029/97JD01864.
- Tiedtke, M., 1989: A comprehensive mass flux scheme for cumulus parameterization in large-scale models. *Mon. Wea. Rev.*, 117, 1779-1800.
- Williamson, D. L., 1968: Integration of the barotropic vorticity equation on a spherical geodesic grid. *Tellus*, 20, 642-653.
- Zienkiewicz, O. C., 1979: "The Finite Element Method", 3rd Ed., McGraw-Hill, London, pp. 164-167.